

Basic Unit 07 KT 94-S

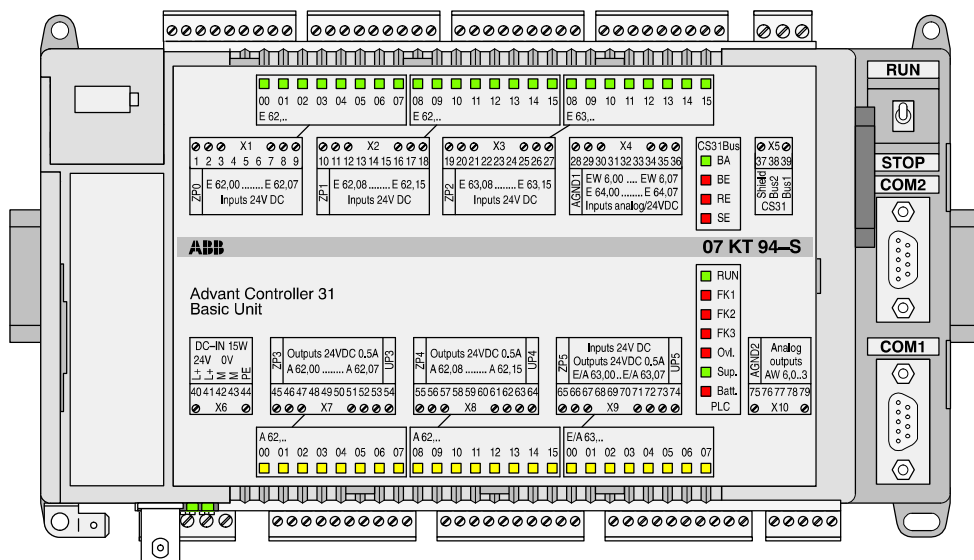

4 Basic Unit 07 KT 94-S

Basic unit with max. 240 kB user program
+ 120 kB user data, CS31 system bus

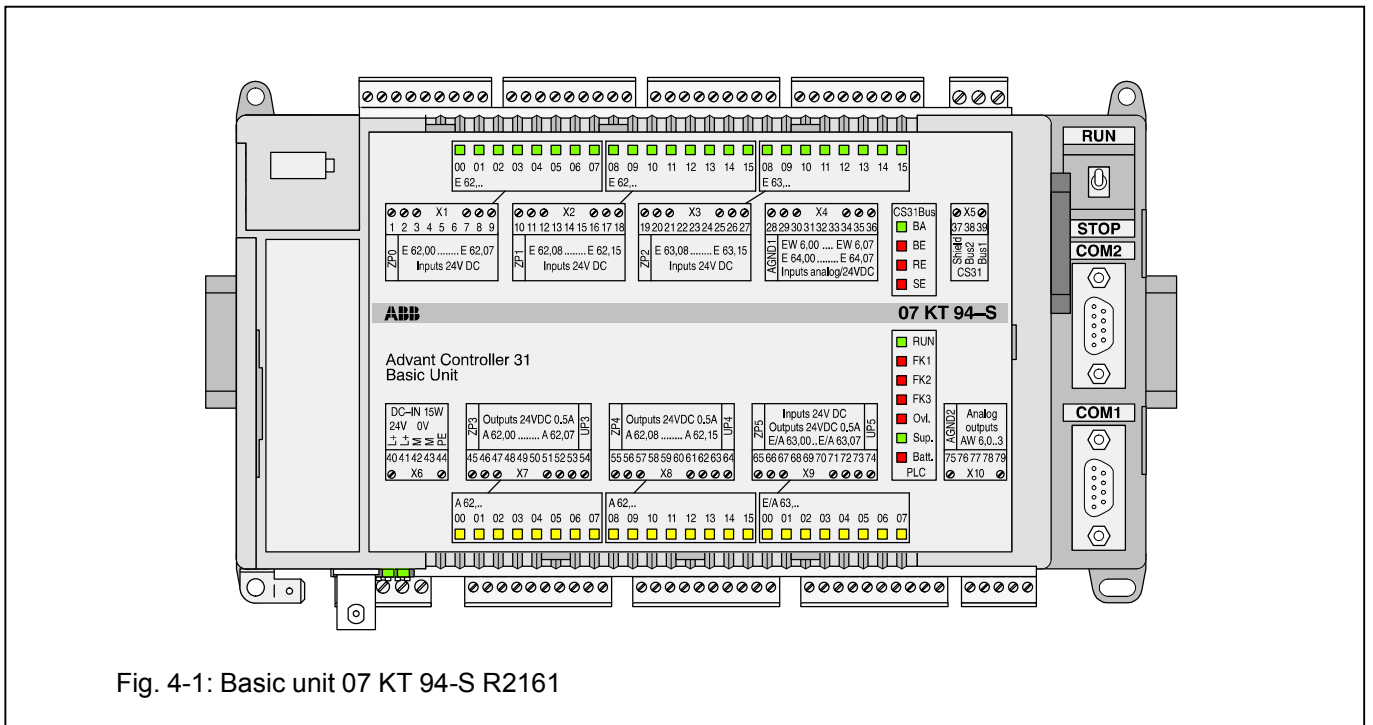

Fig. 4-1: Basic unit 07 KT 94-S R2161

Contents	4.5	SmartMedia Card	4-30
4.1 Brief description	4.6	High-speed counter	4-32
4.1.1 Main features	4.7	Technical data 07 KT 94-S	4-37
4.1.2 Project planning / Start-up	4.7.1	General data	4-37
4.2 Front view	4.7.2	Power supply	4-37
4.3 Structure of the front panel	4.7.3	Lithium battery	4-38
4.3.1 Terminal assignment overview	4.7.4	Digital inputs	4-38
4.4 Electrical connection	4.7.5	Digital outputs	4-38
4.4.1 Application example for	4.7.6	Digital inputs/outputs	4-39
input and output wiring	4.7.7	Analog inputs	4-39
4.4.2 Connecting the supply voltage	4.7.8	Analog outputs	4-40
4.4.3 Connection of the CS31 system bus	4.7.9	Connection of serial interface COM1	4-41
4.4.4 Connection of the digital inputs	4.7.10	Connection of serial interface COM2	4-41
4.4.5 Connection of the digital outputs	4.7.11	Connection to the CS31 system bus	4-41
4.4.6 Connection of the digital inputs/outputs ...	4.7.12	LED displays	4-42
4.4.7 Connection of the 8 konfigurabile	4.7.13	High-speed hardware counter	4-42
analog inputs	4.7.14	Mechanical data	4-43
4.4.8 Connection of the 4 konfigurabile	4.7.15	Mounting hints	4-44
analog outputs	4.7.16	Ordering data	4-44
4.4.9 Battery and battery replacement	4.10	MODBUS communication via COM2	4-45
4.4.10 Serial interface COM1	4.11	Description ARCNET	4-57
4.4.11 Serial interface COM2			
4.4.12 Networking interface			

Features of the basic units

Basic unit	07 KT 94-S R2101	07 KT 94-S R2161		
User program	240 kB	240 kB		
User data	120 kB	120 kB		
Digital inputs	24	24		
Digital outputs	16	16		
Digital inputs/outputs	8	8		
Analog inputs	8	8		
Pt100	yes	yes		
Analog outputs	4	4		
20 mA	yes	yes		
Are the analog inputs configurable as digital inputs	yes	yes		
Serial interfaces	COM1 COM2	COM1 COM2		
Modbus via COM2	yes	yes		
Parallel interface for connecting a coupler	yes	yes		
ARCNET via BNC	no	yes		

4.1 Brief description

The basic unit 07 KT 94-S works either as

- bus master in the decentralized automation system Advant Controller 31-S or as
- slave (remote processor) in the decentralized automation system Advant Controller 31-S or as
- stand-alone central unit.

The device has a 24 V DC power supply voltage.

4.1.1 Main features

- 24 digital inputs with LED displays
- 16 digital transistor outputs with LED displays
- 8 digital inputs/outputs with LED displays
- 8 **individually configurable** analog inputs 0...10 V, 0...5 V, ± 10 V, ± 5 V, 0...20 mA, 4...20 mA, differential inputs, Pt100 (2-wire or 3-wire), the analog inputs are also individually configurable as digital inputs
- 4 **individually configurable** analog outputs ± 10 V, 0...20 mA, 4...20 mA
- 2 counters for counting frequencies up to 50 kHz, configurable in 7 different operating modes
- 1 CS31 system bus interface for system expansion
- 1 interface for connecting communication modules (e.g. 07 KP 90)
- Serial interface COM1
 - is set as programming interface
 - can be set as an ASCII interface for connecting peripheral devices (e.g. MMC devices)
- Serial interface COM2
 - as an ASCII interface for connecting peripheral devices (e.g. MMC devices)
 - MODBUS master and slave interface
- Real-time clock
- LEDs for displaying operating conditions and error messages
- Detachable screw-type terminal blocks
- Fastening by screws or by snapping the device onto a DIN rail
- The lithium battery 07 LE 90 can be put into the battery compartment in order to
 - store and back-up the user program in the RAM
 - store and back-up data which is additionally contained in the RAM, e.g. the status of flags
 - back-up the time and date (real-time clock)
- RUN/STOP switch for starting and aborting the program execution.

- Extensive diagnosis functions
 - Self-diagnosis of the basic unit
 - Diagnosis of the CS31 system bus and the connected modules
- Integrated Flash EPROM for storing program and data
- Exchangable Smart Media Card 07 MC 90 for user data or for updating the operating system or PLC program.

4.1.2 Project planning / start-up

The following has to be observed for project planning and start-up:

- Programming is performed using AC31 programming software, which can be run on commercially available IBM compatible PCs (see documentation for the programming system 907 PC 331)
- The regulations written in the safety manual 907 PC 339 have to be fulfilled for each safety user program.
- The processor processes the user program contained in the RAM. It is loaded into the RAM via the serial interface COM1/COM2 or via the SmartMedia Card and can also be changed there. An additional save command is used to save the program in the Flash EPROM.

Note: In the course of the following operations

- Power 'ON'
- RUN/STOP switch from STOP --> RUN
- Program start-up with programming system
- Cold start of the PLC
- Warm start of the PLC

the RAM is overwritten by the contents of the Flash EPROM, if a user program is contained in the Flash EPROM.

- Online program modification
A quick modification of the user program is possible without interrupting the operation (see programming system 907 PC 331).
- Change-over between the operating modes
 - Stand-alone basic unit
 - Bus master basic unit and
 - Slave basic unit

The basic unit is set to "Stand-alone" upon delivery. Changing the application mode is carried out in the following three steps:

1. Change the system constant KW 0,0 in the PLC, see chapter A7.3 (Appendix), System constants
2. Save the user program in the Flash EPROM or use a battery for back-up

3. Activate new operating mode by:

- calling up the menu item of "Enable PLC mode" in the ABB programming and test system or
 - performing a warm start
 - performing a cold start or
 - power OFF/ON.
- Setting the cycle time
see chapter B1 (Appendix), Processing times
 - Addressing when remote modules are connected
see chapter B2 (Appendix), Addressing
 - Back-up of data areas
Back-up of data areas, i.e. saving of data during power OFF/ON, is only feasible with built-in battery. The following data can be backed, completely or partly:
 - Binary flags
 - Word flags
 - Double word flags
 - Step chains
 - Historical values

In order to back-up certain data, they have to be excluded from initialization to 0.

- Initialization of data areas
During program start, that data areas are initialized to 0 partly or completely, that are defined by system constants, see chapter B7 (Appendix), System constants.

If no battery is effective or if the system constants are in their default values (factory settings), all of the above mentioned data areas are completely set to 0 after power OFF/ON.
- Reactions on errors of error class 3
The user can configure whether or not the user program is to be aborted automatically, if an class 3 error occurs, see chapter B7 (Appendix), System constants.
- Starting-up the AC31 system after power ON
The user can enter a number of n remote modules in KW 00,09. The user program starts only, i.e. it handles process inputs and outputs only, if at least n remote modules have been adopted into the CS31 system bus cycle, see chapter B7 (Appendix), System constants.

4.2 Front view

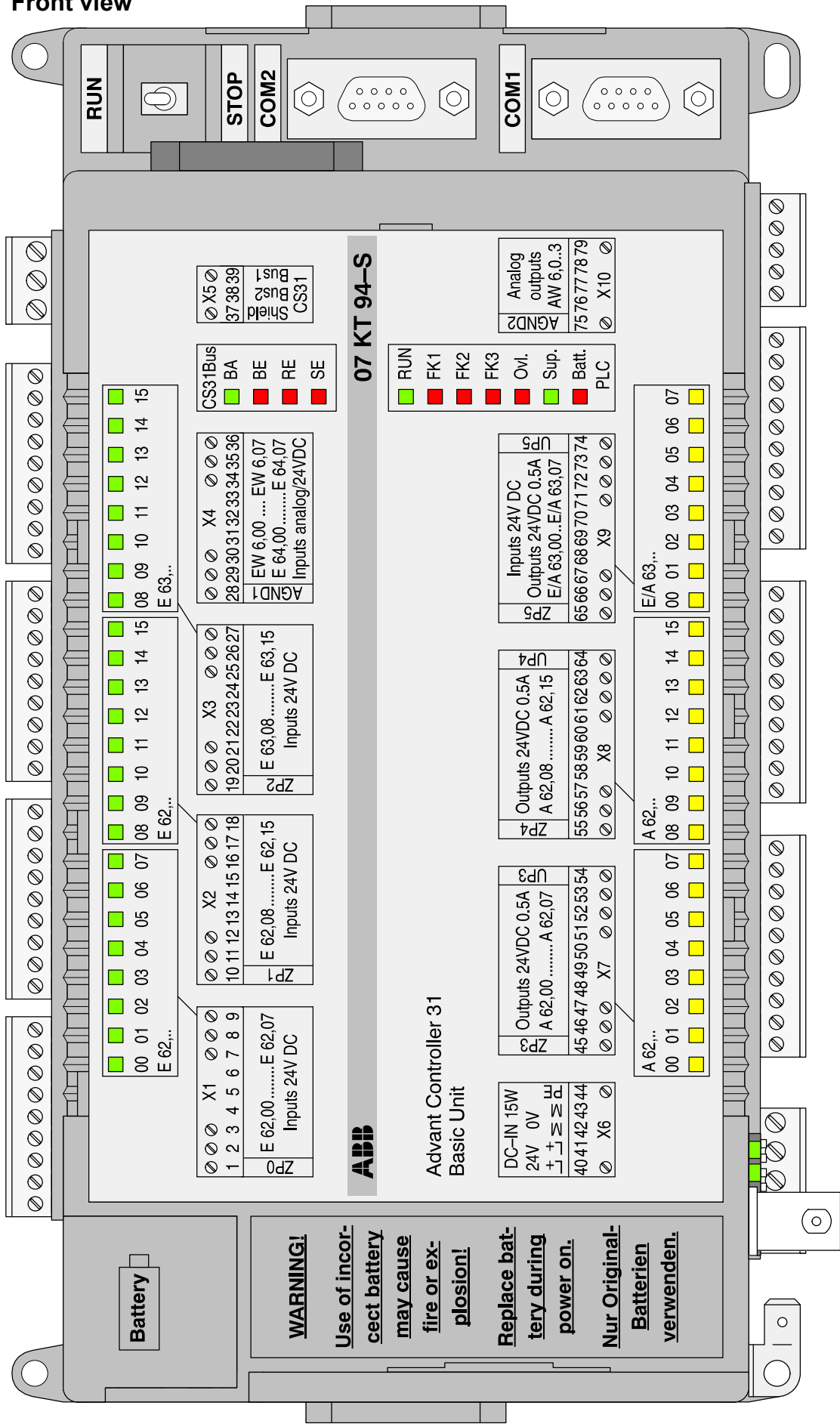

Fig. 4-2: Front view 07 KT 94-S R2161

4.3 Structure of the front panel

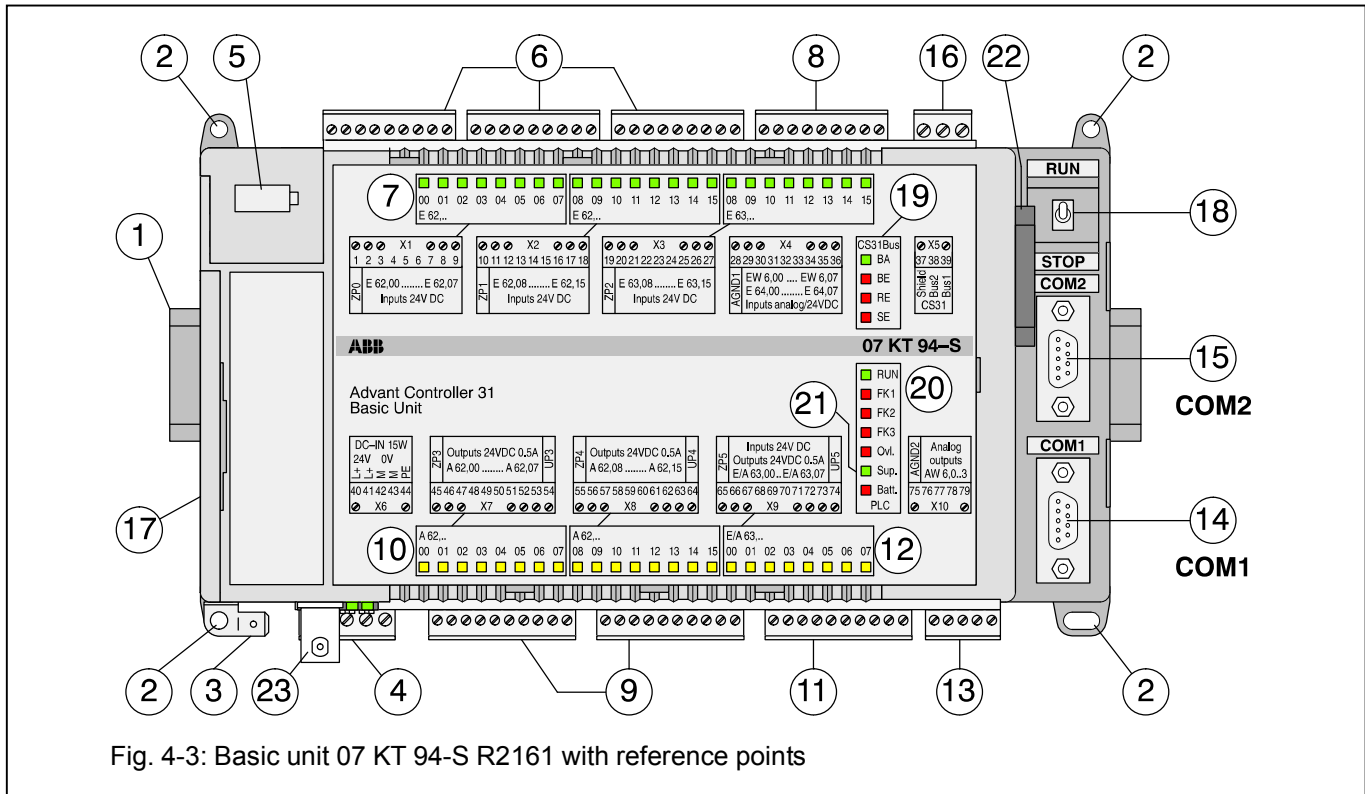

Fig. 4-3: Basic unit 07 KT 94-S R2161 with reference points

- | | | | | | | | | | | | | | | | | | | | | | | | | | | | | | | | | | | |
|---|--|-------------------------------------|-----------|------------|----|---------|-----------|----|---------|-------------------|----|---------|-------------------|-----|-----------|------------------------|-----|---------|-------------|-----|---------|---------------|-----|---------|-------------|-----------|---------|-------------------------------------|--------|-----------|--------------------------|---------|---------|----------------------------|
| <p>(1) Fastening the device on DIN rail</p> <p>(2) Fastening the device by screws</p> <p>(3) Fasten earthing terminal 6.3 mm</p> <p>(4) Supply voltage connection 24 V DC</p> <p>(5) Battery compartment</p> <p>(6) 24 digital inputs in 3 groups</p> <p>(7) 24 green LEDs for the digital inputs</p> <p>(8) 8 individually configurable analog inputs in one group 0...10 V, 0...5 V, ± 10 V, ± 5 V, 0...20 mA, 4...20 mA, Pt100 (2-wire or 3-wire), differential inputs, the analog inputs are also individually configurable as digital inputs</p> <p>(9) 16 digital transistor outputs in two groups</p> <p>(10) 16 yellow LEDs for the digital outputs</p> <p>(11) 8 digital inputs/outputs in one group</p> <p>(12) 8 yellow LEDs for the digital inputs/outputs</p> <p>(13) 4 individually configurable analog outputs ± 10 V, 0...20 mA, 4...20 mA in one group</p> <p>(14) Serial interface COM1 (programming, MMC)</p> <p>(15) Serial interface COM2 (MMC)</p> | <p>(16) Connection for CS31 system bus</p> <p>(17) Cover of the interface for the connection of communication modules (may only be removed for connecting communication modules)</p> <p>(18) Switch for RUN/STOP operation:
With the RUN/STOP switch the execution of the user program is started or stopped.</p> <p>(19) LED displays for CS31 system bus</p> <table border="0"> <tr> <td>BA</td> <td>LED green</td> <td>Bus active</td> </tr> <tr> <td>BE</td> <td>LED red</td> <td>Bus error</td> </tr> <tr> <td>RE</td> <td>LED red</td> <td>Remote unit error</td> </tr> <tr> <td>SE</td> <td>LED red</td> <td>Serial unit error</td> </tr> </table> <p>(20) LED displays for RUN and error class</p> <table border="0"> <tr> <td>RUN</td> <td>LED green</td> <td>User progr. is running</td> </tr> <tr> <td>FK1</td> <td>LED red</td> <td>Fatal error</td> </tr> <tr> <td>FK2</td> <td>LED red</td> <td>Serious error</td> </tr> <tr> <td>FK3</td> <td>LED red</td> <td>Light error</td> </tr> </table> <p>(21) Other LED displays</p> <table border="0"> <tr> <td>Over-load</td> <td>LED red</td> <td>Overload/short-circuit at an output</td> </tr> <tr> <td>Supply</td> <td>LED green</td> <td>Supply voltage available</td> </tr> <tr> <td>Battery</td> <td>LED red</td> <td>Batt. not effective</td> </tr> </table> <p>(22) Insertable SmartMedia Card for operating system, user program and user data</p> <p>(23) ARCNET BNC connector only for R2161
Not available for R2101</p> | BA | LED green | Bus active | BE | LED red | Bus error | RE | LED red | Remote unit error | SE | LED red | Serial unit error | RUN | LED green | User progr. is running | FK1 | LED red | Fatal error | FK2 | LED red | Serious error | FK3 | LED red | Light error | Over-load | LED red | Overload/short-circuit at an output | Supply | LED green | Supply voltage available | Battery | LED red | Batt. not effective |
| BA | LED green | Bus active | | | | | | | | | | | | | | | | | | | | | | | | | | | | | | | | |
| BE | LED red | Bus error | | | | | | | | | | | | | | | | | | | | | | | | | | | | | | | | |
| RE | LED red | Remote unit error | | | | | | | | | | | | | | | | | | | | | | | | | | | | | | | | |
| SE | LED red | Serial unit error | | | | | | | | | | | | | | | | | | | | | | | | | | | | | | | | |
| RUN | LED green | User progr. is running | | | | | | | | | | | | | | | | | | | | | | | | | | | | | | | | |
| FK1 | LED red | Fatal error | | | | | | | | | | | | | | | | | | | | | | | | | | | | | | | | |
| FK2 | LED red | Serious error | | | | | | | | | | | | | | | | | | | | | | | | | | | | | | | | |
| FK3 | LED red | Light error | | | | | | | | | | | | | | | | | | | | | | | | | | | | | | | | |
| Over-load | LED red | Overload/short-circuit at an output | | | | | | | | | | | | | | | | | | | | | | | | | | | | | | | | |
| Supply | LED green | Supply voltage available | | | | | | | | | | | | | | | | | | | | | | | | | | | | | | | | |
| Battery | LED red | Batt. not effective | | | | | | | | | | | | | | | | | | | | | | | | | | | | | | | | |

4.3.1 Terminal assignment overview

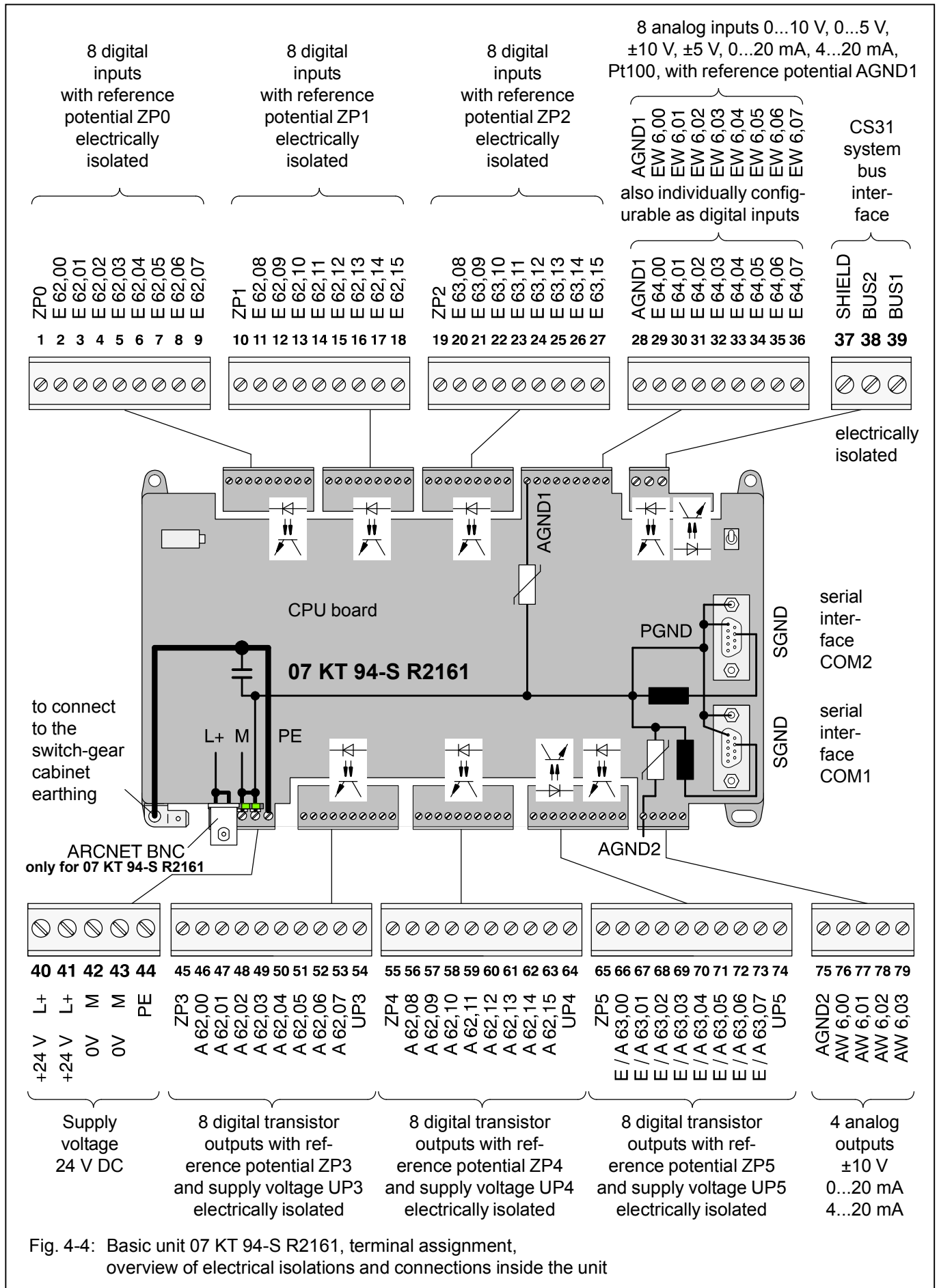

Fig. 4-4: Basic unit 07 KT 94-S R2161, terminal assignment, overview of electrical isolations and connections inside the unit

4.4 Electrical connection

4.4.1 Application example for input and output wiring

The following illustration shows an application example in which different possibilities for wiring inputs and outputs are used.

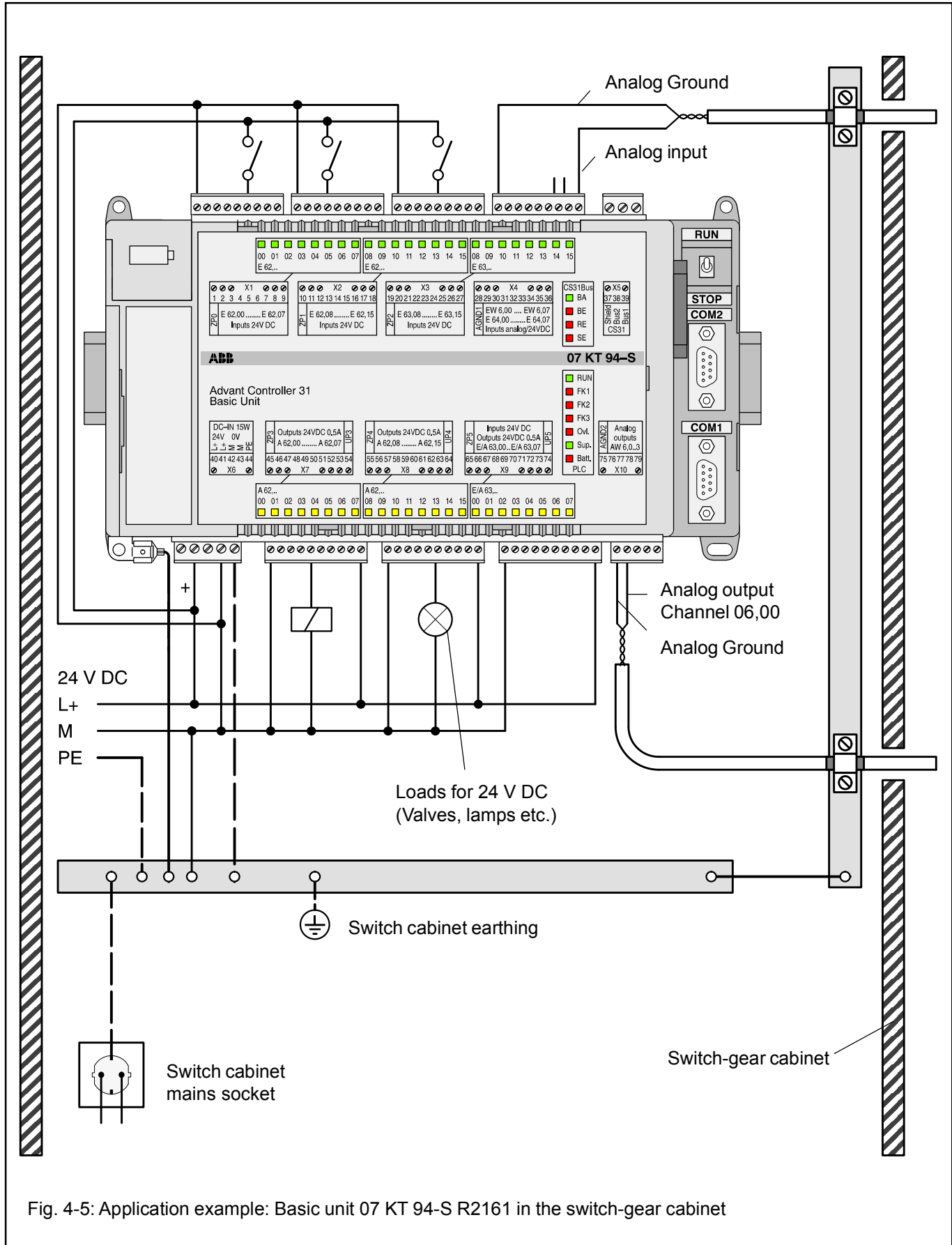

Fig. 4-5: Application example: Basic unit 07 KT 94-S R2161 in the switch-gear cabinet

Please observe in particular:

- The earthing measures
- The handling of the electrically isolated input groups
- The handling of the electrically isolated output groups
- The connection of shielded analog cables
- The earthing of the switch-gear cabinet mains socket

4.4.2 Connection of the supply voltage

The 24 V DC supply voltage is connected via a 5-pole detachable screw-type terminal block.

Attention: Plug and unplug terminal block only with power is off!

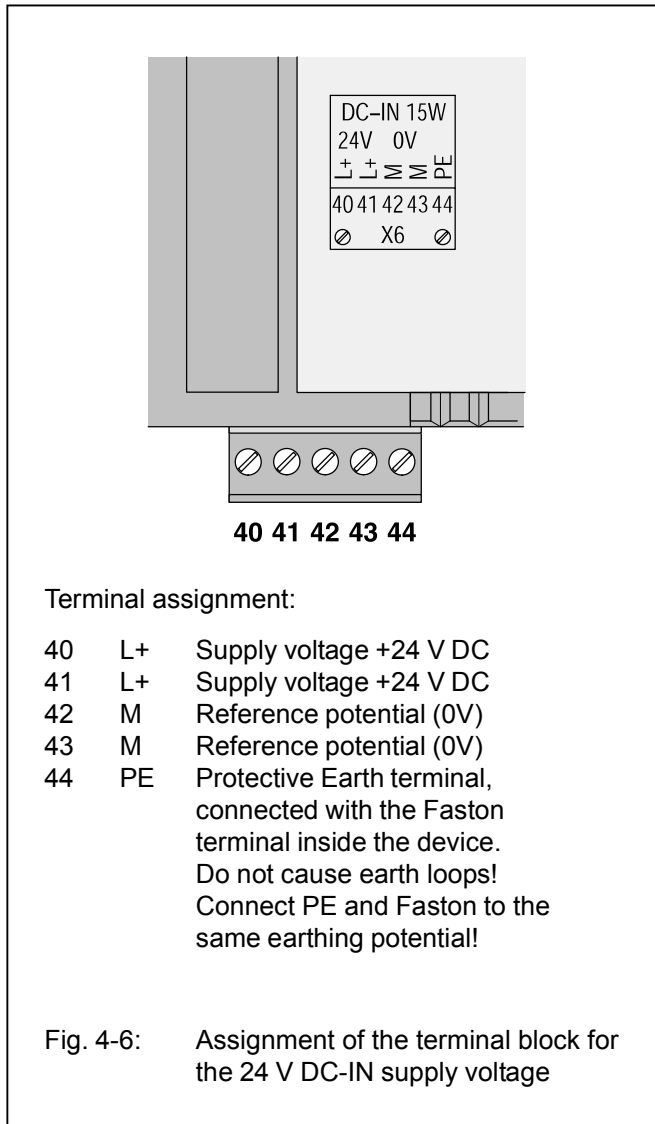

The terminals 40 and 41 (L+) as well as 42 and 43 (M) are connected to each other via the printed circuit board. If the power supply is looped through, these two connections must not be burdened with currents higher than **4 A**.

Please take also into consideration that supply voltages which are looped through are disconnected for the following devices when the plug is withdrawn.

If higher currents are to be conducted without interruption possibility, the two wires for M have to be connected under the same terminal. The same applies for L+.

4.4.3 Connection for the CS31 system bus

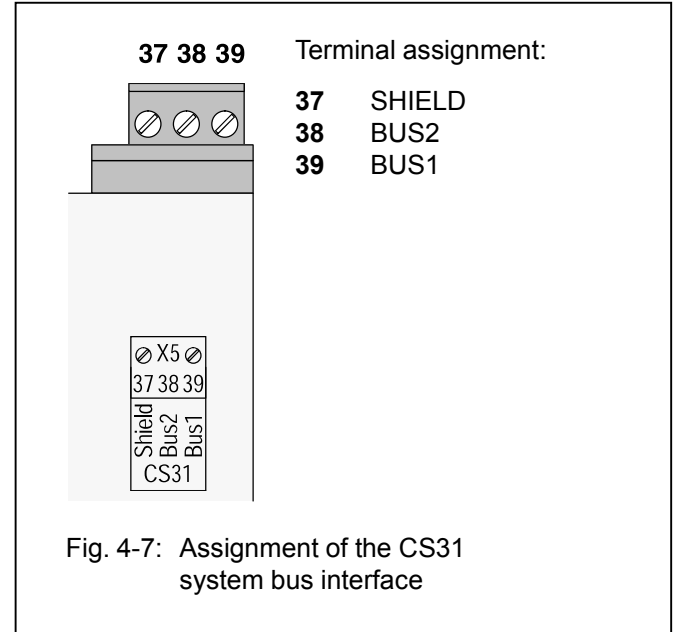

The connection to the CS31 system bus is made by means of a 3-pole detachable terminal block. Please observe:

- All of the AC31 devices, no matter whether they are master or slave devices, are connected with twisted-pair bus line as follows:
 - One core of the bus line is looped through via the BUS1 terminals of all devices to be connected to the CS31 system bus.
 - The other core of the bus line is looped through via the BUS2 terminals of all devices to be connected to the CS31 system bus.
- If the basic unit 07 KT 94-S is located at the beginning or at the end of the bus line, the bus terminating resistor (120 Ω) has to be connected additionally between the BUS1 and BUS2 terminals.
- The shield of the twisted-pair bus line is looped through via the SHIELD terminals of all the devices to be connected to the CS31 system bus.
- The handling of the CS31 system bus is described in detail in volume 2, System data.

4.4.4 Connection of the digital inputs

The digital inputs must not be used for safety-relevant applications.

The following figure shows the assignment of the 24 digital inputs.

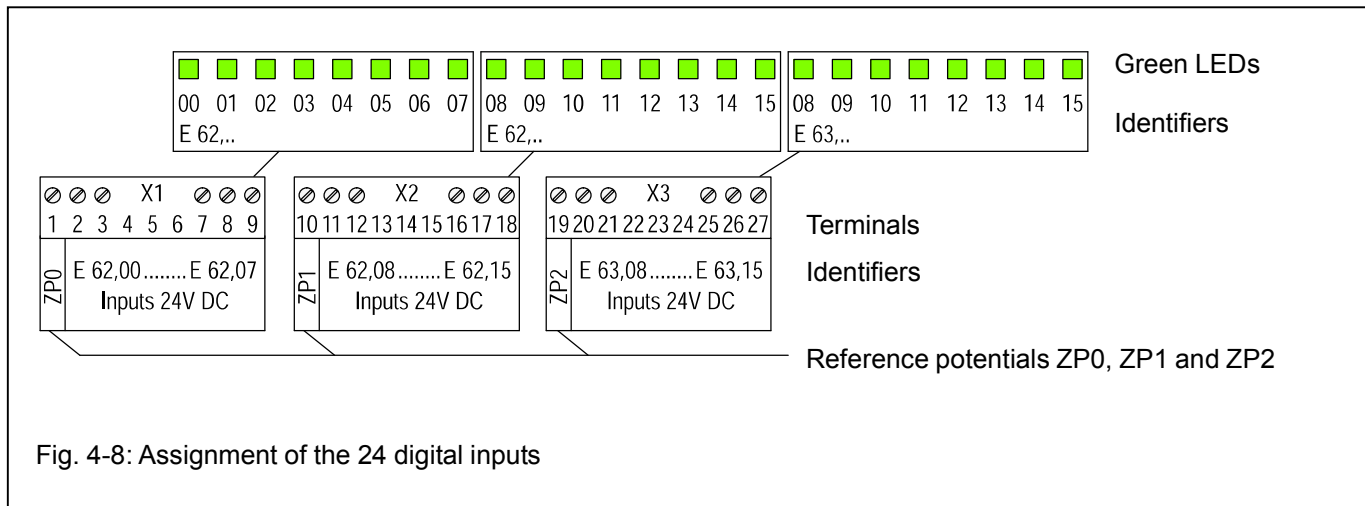

Fig. 4-8: Assignment of the 24 digital inputs

Features:

- The 24 digital inputs are arranged in three groups of 8 inputs each.
- The three groups E 62,00...E 62,07, E 62,08...E 62,15 and E 63,08...E 63,15 are electrically isolated from each other.
- The inputs use 24V signals in positive logic (1 = +24 V).
- The signal delay of the inputs is configurable to 7 ms (default) or 1 ms. The configuration is performed by setting certain bits in the system constants KW 85,00 and KW 85,01 as follows:

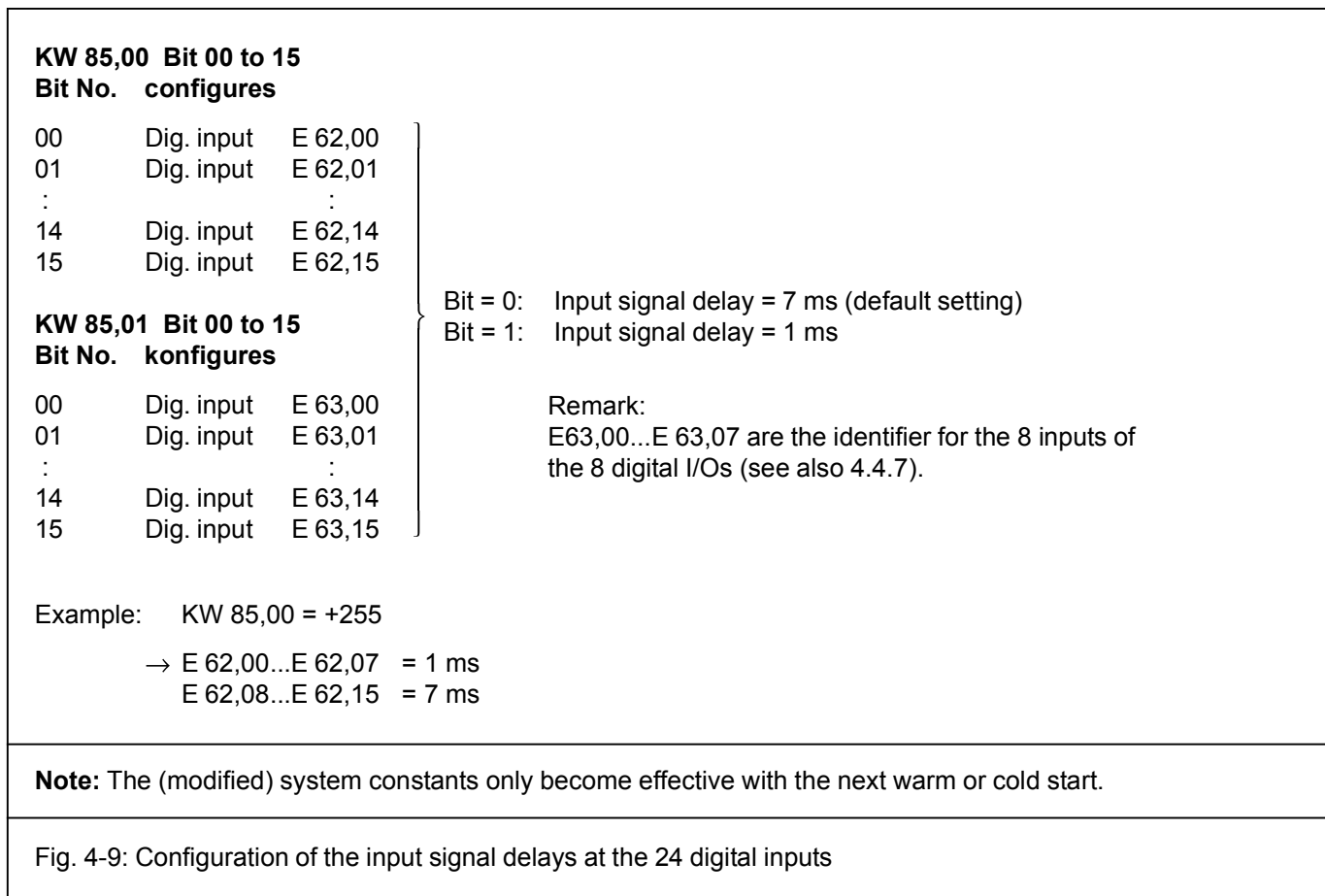
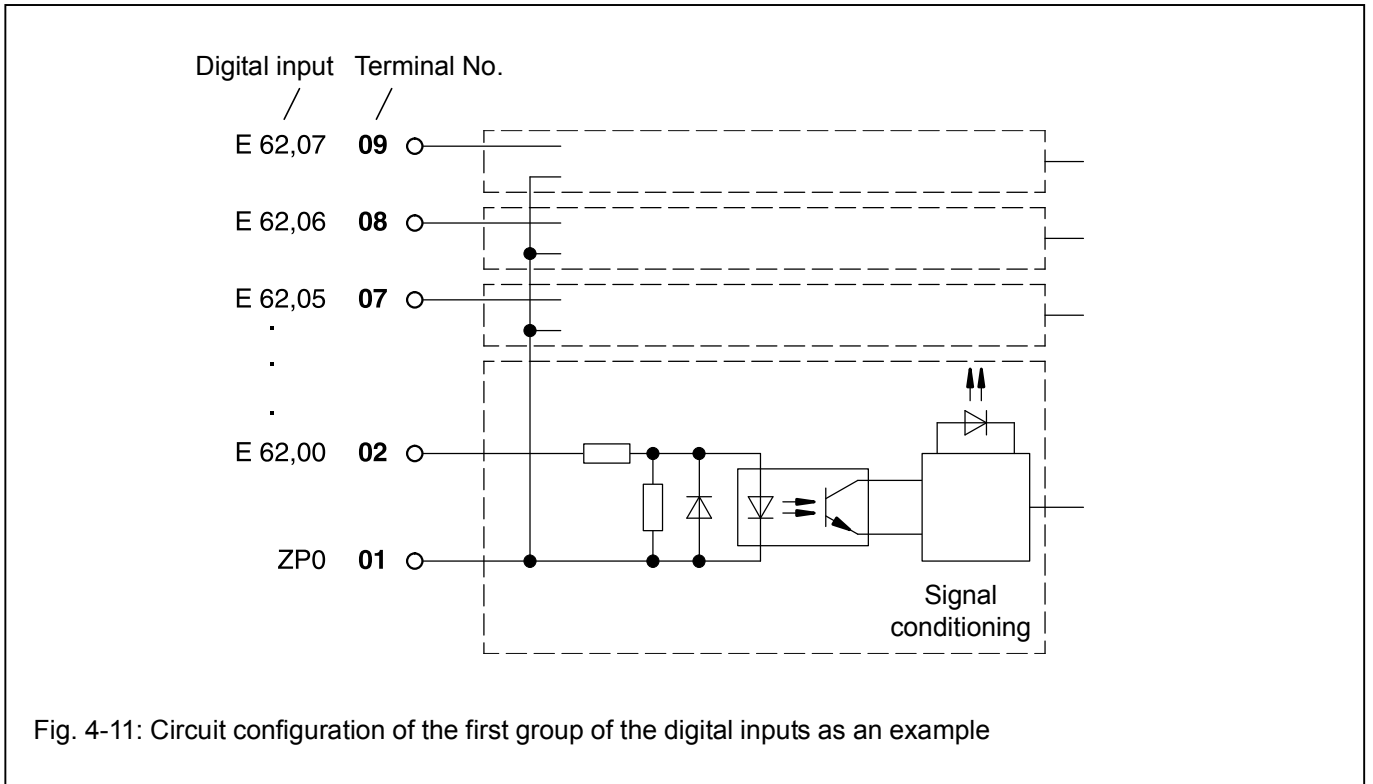

Fig. 4-9: Configuration of the input signal delays at the 24 digital inputs

- The circuit configuration of the first group of the digital inputs is shown as an example in the following.



Use of the input signals at the terminals 2 and 3 (E 62,00 and E 62,01) for the high-speed counter

The two inputs **E 62,00** and **E 62,01** can be assigned to the internal high-speed counter by configuration. If the counter is used and therefore configured to one of its possible operating modes, these two inputs are only avail-

able for the counter. If the two inputs are to use as normal digital inputs, it has to be made sure, that the high-speed counter is configured to the operating mode "No counter". This operating mode is the default setting (see also the chapter "High-speed counter").

4.4.5 Connection of the digital outputs

The digital outputs must not be used for safety-relevant applications.

The following figure shows the assignment of the 16 digital outputs.

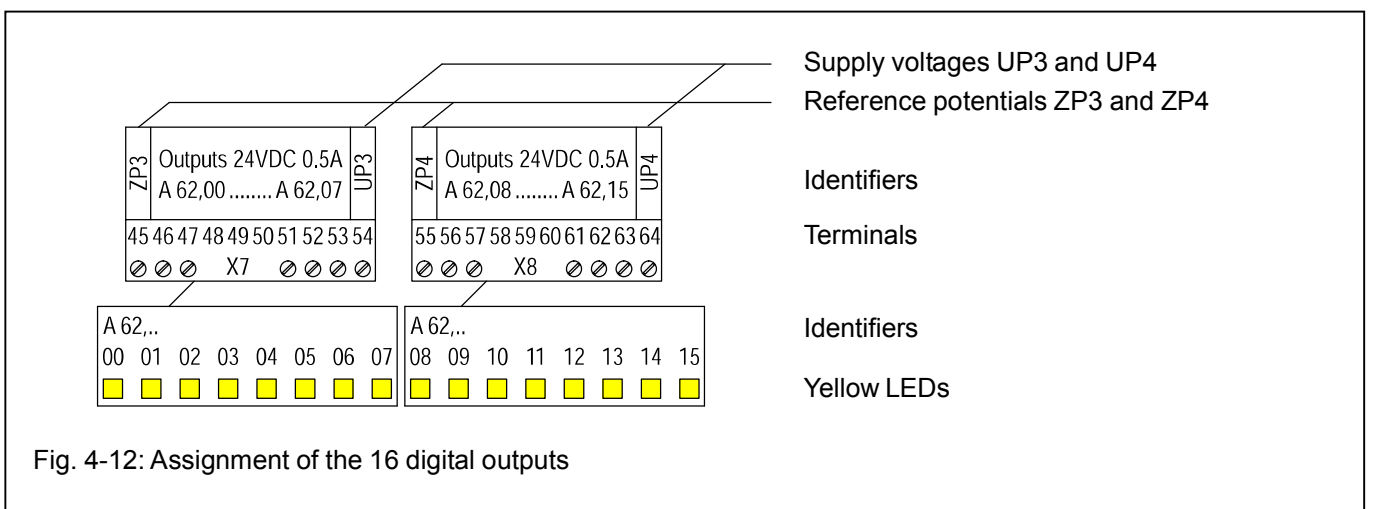

Features of the digital outputs:

- The 16 digital outputs are arranged in two groups of 8 outputs each.
- The two groups are electrically isolated from each other.
- The outputs can be loaded with a rated current of 500 mA.
- Each group as a whole is electrically isolated from the rest of the device.
- The outputs employ semiconductors and are short-circuit and overload-proof.
- The outputs are automatically switched off in case of overload or short-circuit.
- An overall error message indicates whether a short-circuit or an overload has occurred on a output group.
- The overload is displayed by the red LED Ovl. and via error flags in the PLC.

- The red LED Ovl. goes out when the overloaded output is switched on again automatically.
- The acknowledgement of the error message, i.e. the resetting of the error flags, is carried out according to chapter B4.8 (Appendix), Acknowledgement of error messages in the basic unit.
- The outputs are safe against reverse polarity and forced supply of 24 V DC.

Use of the digital output signal at the terminal 46 (A 62,00) for the high-speed counter

The output **A 62,00** can be assigned to the internal high-speed counter by configuration. If the counter is used in the operating modes 1 or 2 (up-counter), the output A 62,00 is only available for the counter.

If the output is to use as a normal digital output, it has to be made sure, that the high-speed counter is not configured to the operating modes 1 or 2 (see also the chapter "High-speed counter").

Circuit configuration of the digital outputs

The following figure shows the circuit configuration of the digital outputs of the first group as an example.

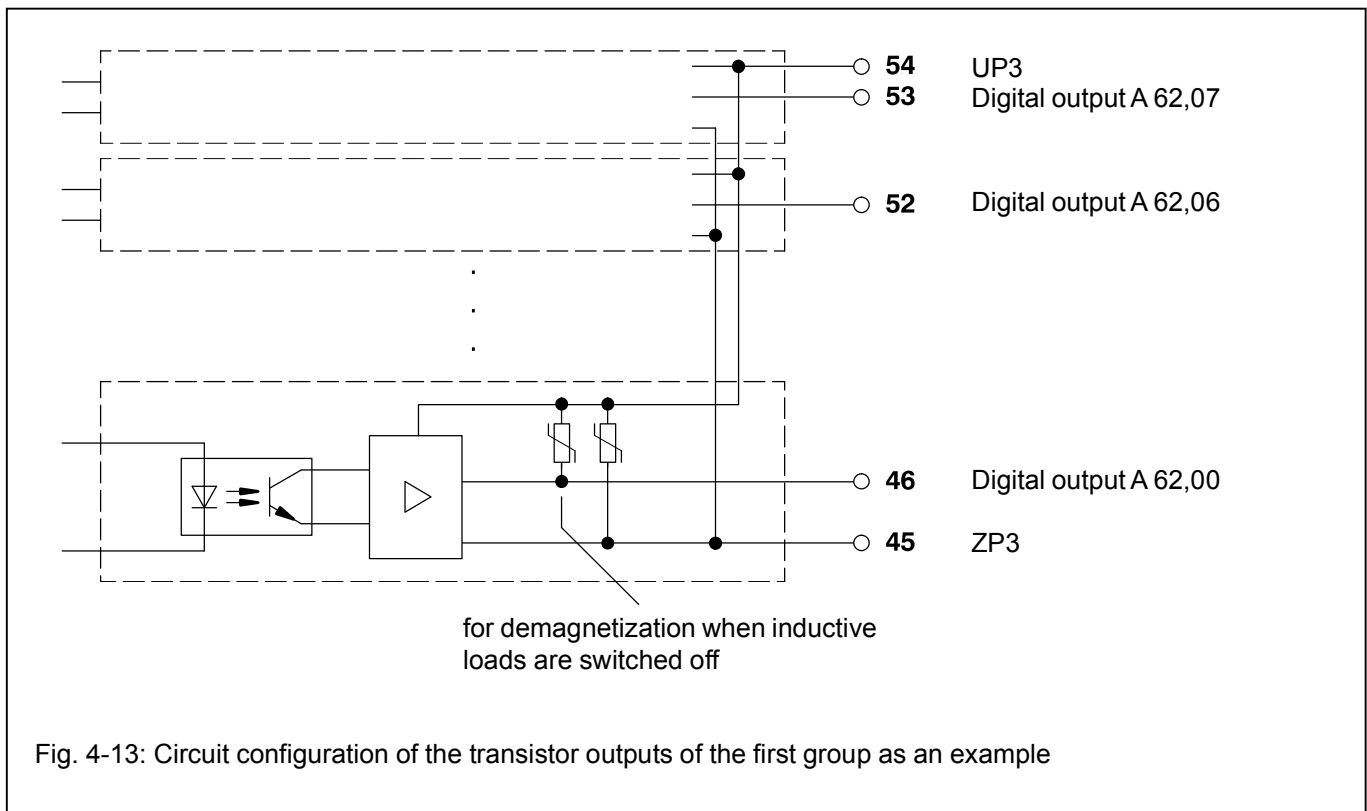
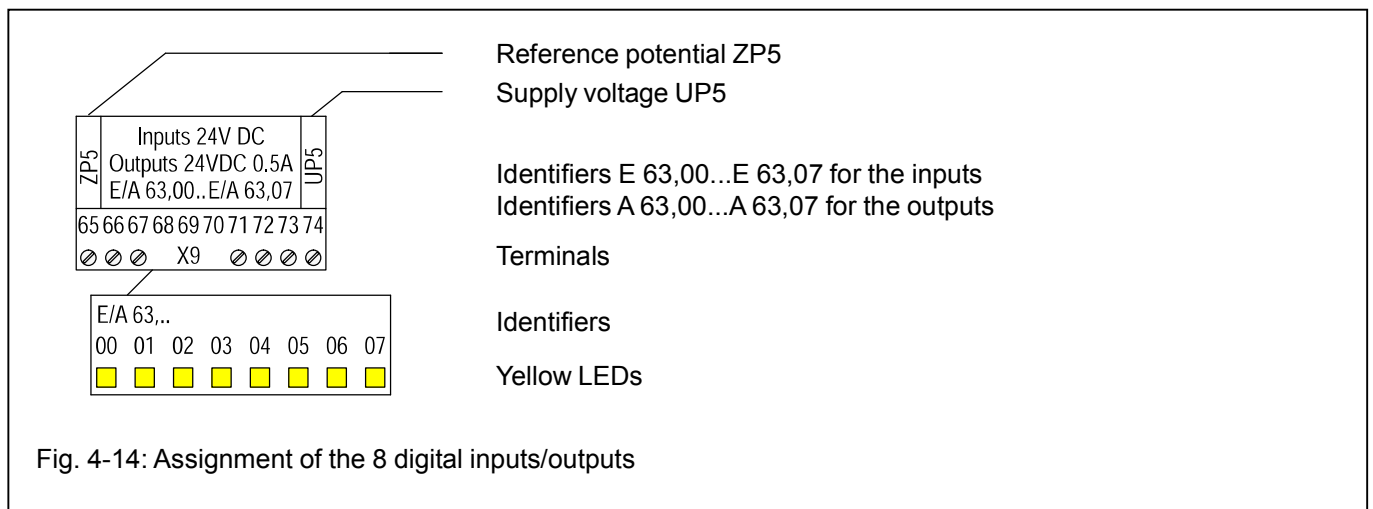

Fig. 4-13: Circuit configuration of the transistor outputs of the first group as an example

4.4.6 Connection of the digital inputs/outputs

The digital inputs/outputs must not be used for safety-relevant applications.

The following figure shows the assignment of the 8 digital inputs/outputs.



Features of the digital inputs/outputs:

- The 8 digital inputs/outputs are arranged in one group.
 - The group as a whole is electrically isolated from the rest of the device.
 - The inputs/outputs can be used individually as input, output or re-readable output.
 - If the terminals are used as digital inputs, the input signal delay can be configured to 7 ms (default) or to 1 ms. The configuration is performed by setting certain bits in the system constant KW 85,01 as follows:
 - If the terminals are used as digital outputs, the output signals "1" are individually monitored by the re-readable input. If the output status is wrong, an overall error message is generated for the involved output group. The error is displayed by the red LED Ovl. and by error flags of the PLC then.
- The error could have been caused by overload, short-circuit or missing supply voltage UP5/ZP5.
- The technical specifications are the same as with the other digital inputs and outputs.

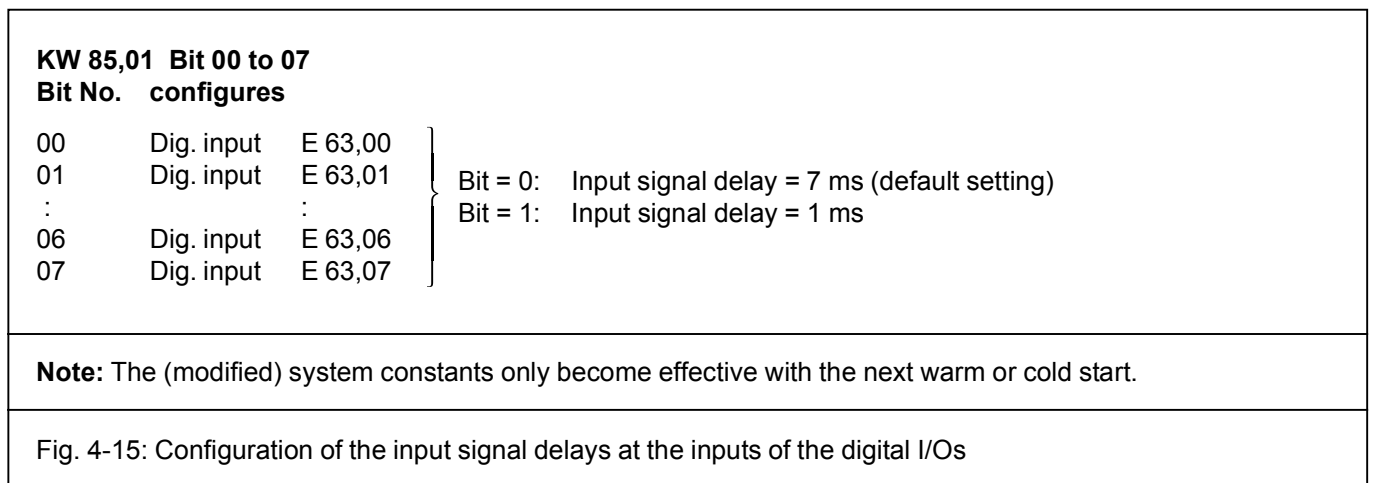

Circuit configuration of the digital inputs/outputs

The following figure shows one of the 8 inputs/outputs of the group as an example.

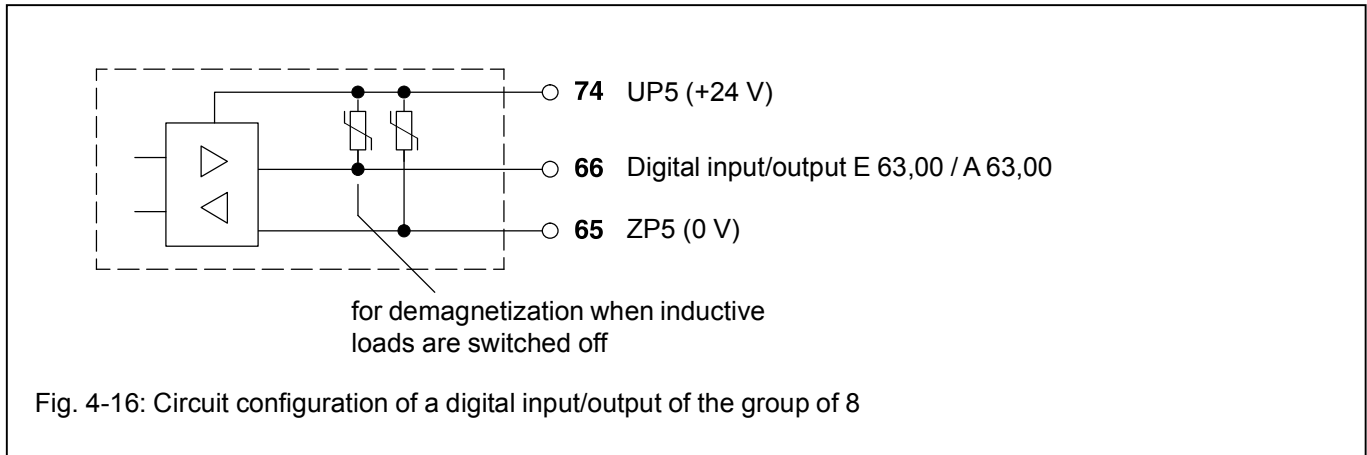

- The technical specifications of the inputs are the same with the other digital inputs, but **with the following exception:**

Caused by the direct electrical connection with the output, the varistor for demagnetization of inductive loads (see figure above) is also in effect at the input.

Therefore, the voltage difference between UP5 and the input signal must not be greater than the limit voltage of the varistor.

The limit voltage of the varistor is ca. 36 V. This means, that if UP5 = 24 V, the input signal voltage must be between -12 V and +30 V. If UP5 = 30 V, the input voltage has to be within -6 V and +30 V.

If all of the 8 channels of the group are used as inputs, and if in addition the UP5 terminal is left unconnected, no restrictions exist for the inputs. The input signal voltages then may be within -30 V and +30 V.

There is no restriction for the input/output group concerning its safety against reversed polarity.

4.4.7 Connection of the 8 configurable analog inputs

The configurable analog inputs must not be used for safety-relevant applications.

The following figure shows the assignment of the 8 analog inputs.

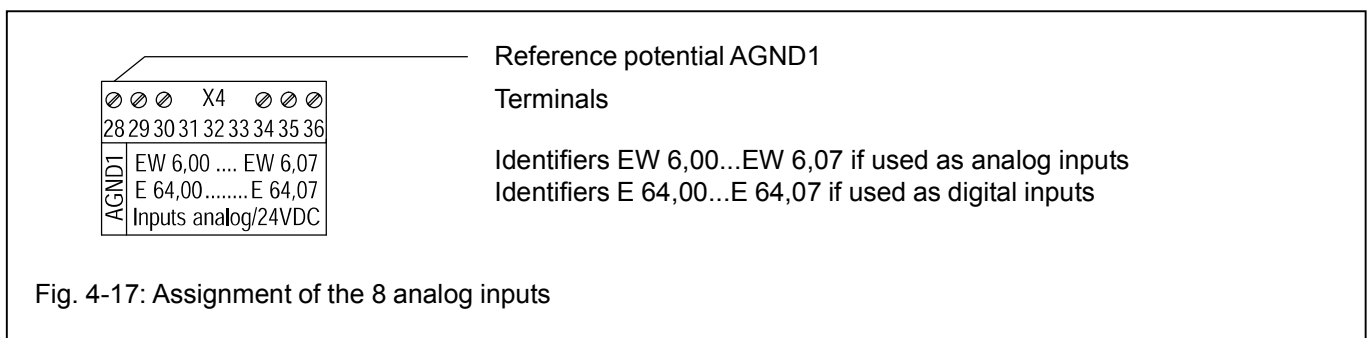

Features of the analog inputs:

- The 8 analog inputs are **not** electrically isolated.
- The resolution of the A/D converter is 12 bits.
- Analog signals are conducted in shielded cables (see Fig. 4-5).
- The analog inputs can be configured individually in a lot of different operating modes (even as digital inputs). The configuration is performed by setting certain bits in the system constants KW 86,00 to KW 86,07 as follows:

<p>The system constant</p> <p>KW 86,00 configures analog input EW 6,00 KW 86,01 configures analog input EW 6,01 KW 86,02 configures analog input EW 6,02 KW 86,03 configures analog input EW 6,03 KW 86,04 configures analog input EW 6,04 KW 86,05 configures analog input EW 6,05 KW 86,06 configures analog input EW 6,06 KW 86,07 configures analog input EW 6,07</p> <p>*) In the operating mode "Pt100 in 3-wire configuration" and in all configurations with differential inputs, two adjacent inputs belong together (e.g. EW 6,00 and EW 6,01).</p> <p>In this cases both inputs must be configured to the desired operating mode. The lower address must be the even address (EW 6,00), the next (higher) address (EW 6,01) the odd one.</p> <p>The converted analog value is available on the higher address (EW 6,01).</p>	<p>Hex value in the Low Byte, bits 07 06 05 04 03 02 01 00 mean:</p> <p>00_H = Analog input 0...10 V (default setting) 01_H = unused 02_H = Digital input with 7 ms input signal delay 03_H = Analog input 0...20 mA 04_H = Analog input 4...20 mA 05_H = Analog input -10...+10 V 06_H = Analog input 0...5 V 07_H = Analog input -5...+5 V 08_H = Analog input Pt100 in 2-wire configuration -50...+400°C 09_H = Analog input Pt100 in 3-wire configuration -50...+400°C* 0A_H = Analog input 0...10 V differential inputs * 0B_H = Analog input -10...+10 V differential inputs * 0C_H = Analog input 0...5 V differential inputs * 0D_H = Analog input -5...+5 V differential inputs * 0E_H = Analog input Pt100 in 2-wire configuration -50...+70°C 0F_H = Analog input Pt100 in 3-wire configuration -50...+70°C *</p> <p>Hex value in the High Byte, bits 15 14 13 12 11 10 09 08 mean:</p> <p>00_H = Plausibility and open-circuit monitoring and short-circuit monitoring (default setting) 01_H = Open-circuit and short-circuit monitoring 02_H = Plausibility monitoring 03_H = No monitoring</p> <p>For details concerning monitoring see "The measuring ranges of the analog input channels"</p>
<p>Note: The (modified) system constants only become effective with the next warm or cold start.</p>	
<p>Fig. 4-18: Configuration of the 8 analog inputs</p>	

Configuration example:

The following is to be configured:

- a) 1 analog input ± 10 V, default monitoring and
- b) 1 analog input Pt100, 3-wire conf., -50...+400 °C, Monitoring: only open-circuit and short-circuit

for a) Selected channel, e.g. **EW 6,00**

Configuration in KW 86,00

High Byte: 00_H = Default monitoring
Low Byte: 05_H = ± 10 V

KW 86,00: 0005_H = **+5 decimal**

for b) Selected channel, e.g. **EW 6,02** (even) and **EW 6,03** (next higher)

Configuration in KW 86,02

High Byte: 01_H = Monitoring: open-circuit and short-circuit
Low Byte: 09_H = Pt100, 3-wire conf., -50...+400 °C

KW 86,02: 0109_H = **+265 decimal**

Configuration in KW 86,03

High Byte: 01_H = Monitoring: open-circuit and short-circuit
Low Byte: 09_H = Pt100, 3-wire conf., -50...+400 °C

KW 86,03: 0109_H = **+265 decimal**

The measured value is available on **EW 6,03**.

The measuring ranges of the analog input channels

Resolution in the PLC system:

The measured values are converted with a resolution of 12 bits, i.e. 11 bits plus sign for voltage and 12 bits without sign for current. The ranges 0...5 V und ±5 V are converted with 10 bits plus sign.

Examples:

Measuring range	Range of numbers
-10 V...0...10 V	-32760 _D ...0...32760 _D 8008 _H ...0000...7FF8 _H
0...20 mA	0...32760 _D 0000...7FF8 _H

Further details can be found in volume 2, chapter 5.1 "General information for the use of analog inputs and outputs".

In order to make sure, that unused input channels have a defined 0V level, they may be shorted to AGND. Unused inputs must be configured with "unused".

The relationship between the analog input signals and the converted numbers is illustrated in the following figures.

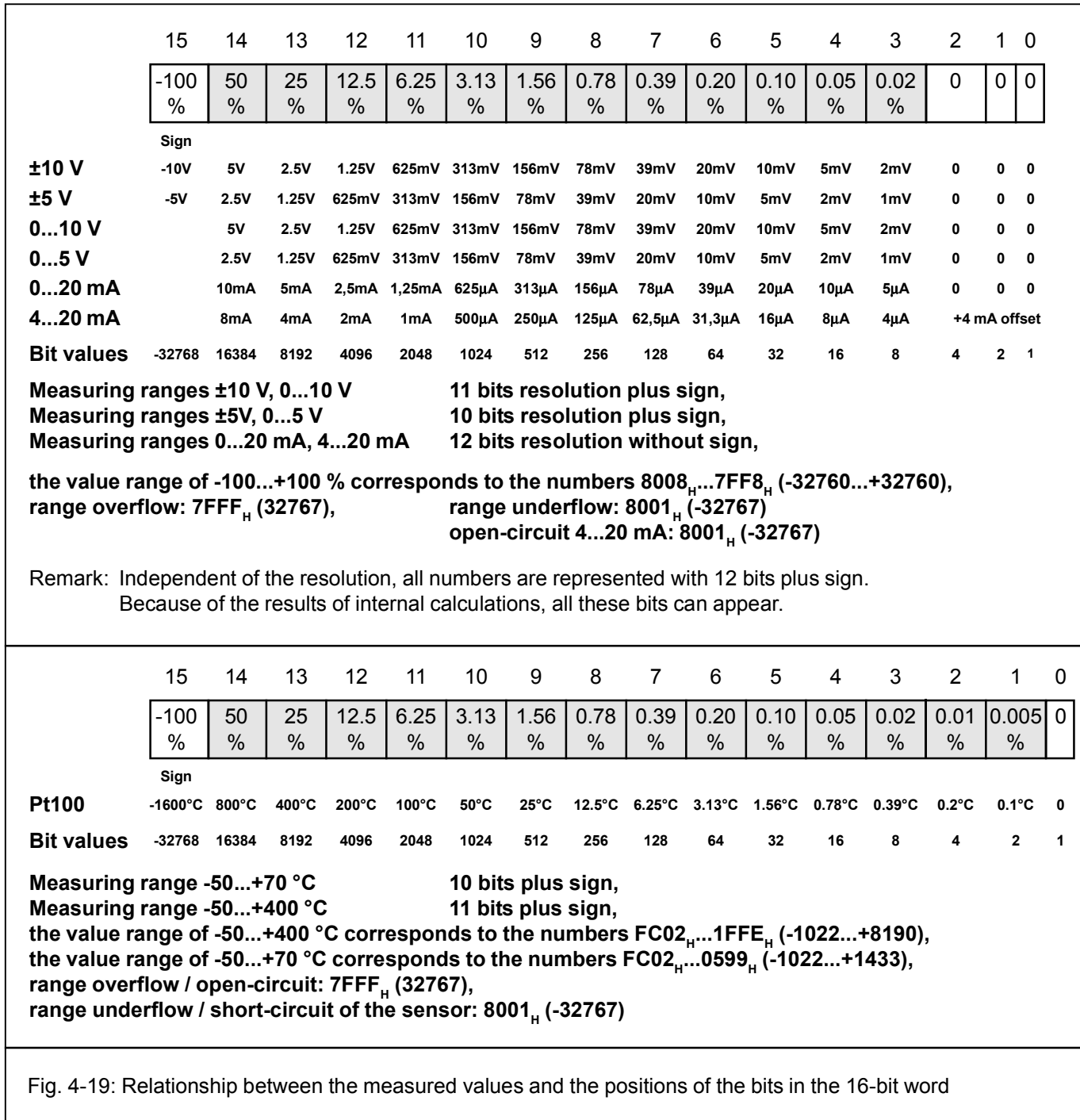

Conversion formula for temperatures:
 A temperature of 400°C results in a numerical value of 8190, i.e.
 +1 K increases the numerical value by 20.475
 Numerical value = $\vartheta/^\circ\text{C} \times 20.475$
 Conversion formula for voltages:
 100 % input voltage results in a numeric value of 32760, i.e. 1 % more input voltage increases the numeric value by 327.6

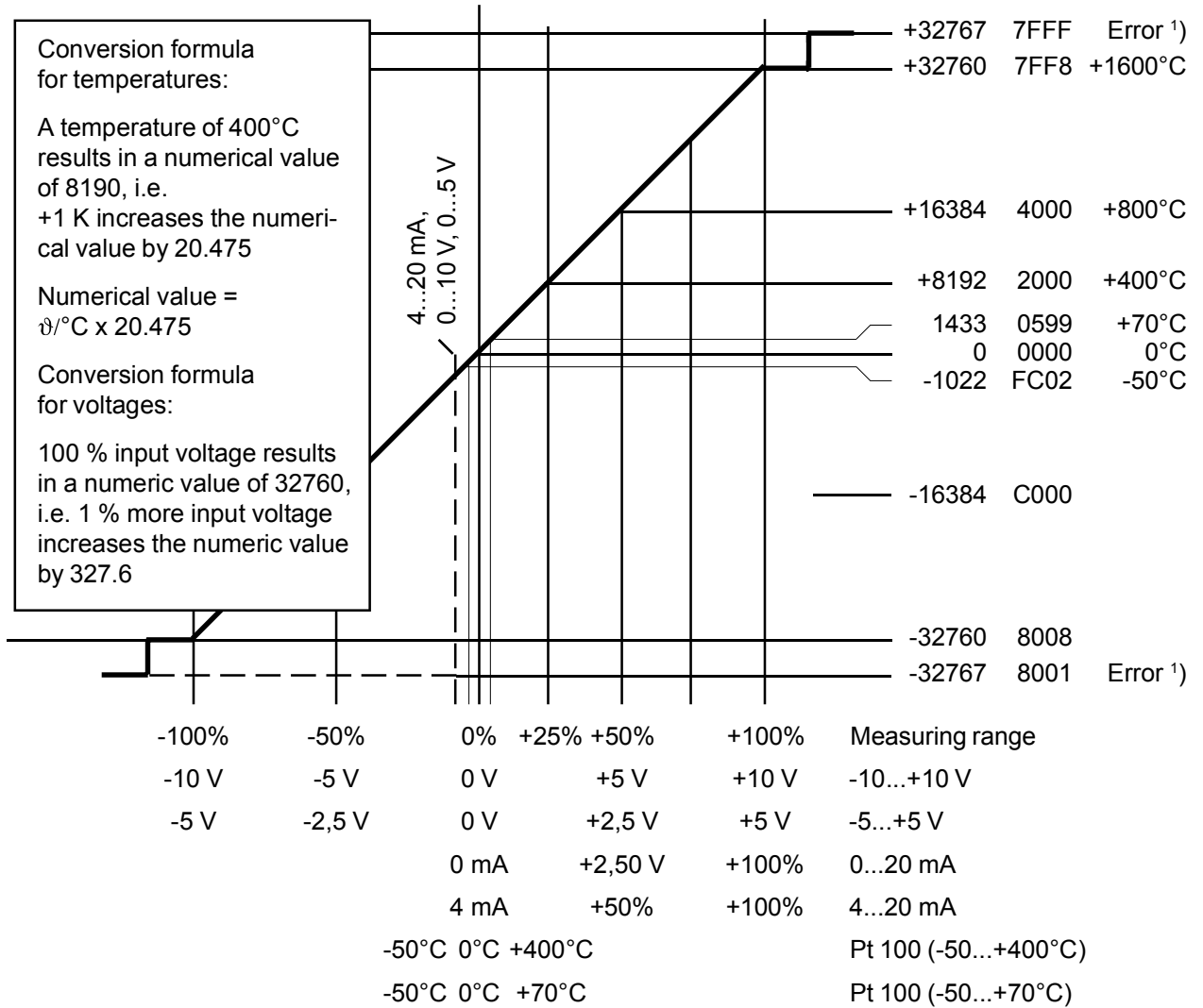

The following is valid for the platinum resistance thermometers:

Pt 100 = Platinum 100 Ω @ 0°C
 Measuring range -50...+400°C
 Measuring range -50...+70°C

The dashed line is valid for the measuring ranges 4...20 mA, 0...10 V and 0...5 V. If in these ranges the measuring value is 2...3 % lower than the lower limit, this is evaluated as a range underflow.

Fig. 4-20: Relationship between measuring value and converted numerical value, voltage input, current input, temperature input

1) In case of a configured plausibility monitoring, range underflow and range overflow by 2...3 % result in an error message (FK4, error number 10). Independent of the configured monitoring, the error values +32767 and -32767 are always generated in case of range underflow and range overflow. Exception: In the measuring range of 0...20 mA only the **range overflow** is detected.

Measuring ranges $\pm 10\text{ V}$ / $\pm 5\text{ V}$ / $0\text{...}10\text{ V}$ / $0\text{...}5\text{ V}$

Input voltages that exceed the measuring range cause the overflow numerical value of +32767. If the measured value is below the range, the underflow numerical value of -32767 is set.

The input impedance is $> 100\text{ k}\Omega$.

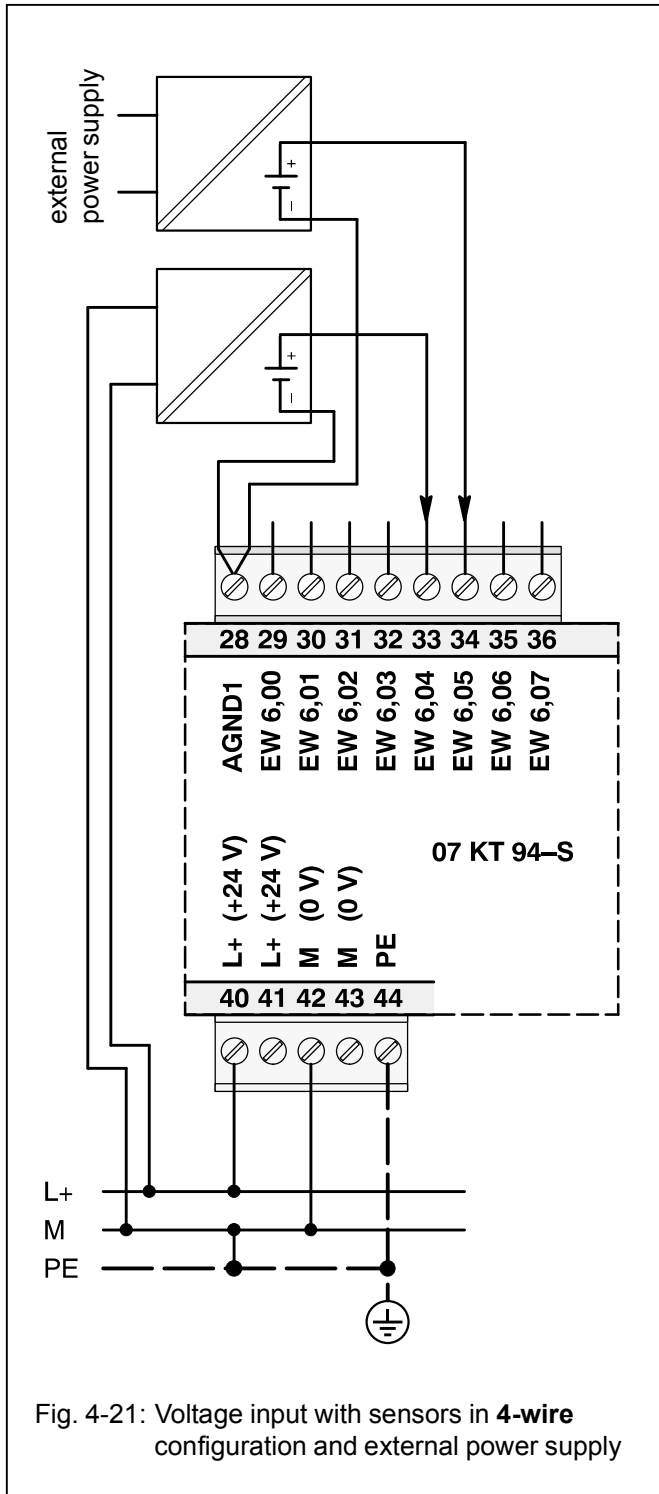

Fig. 4-21: Voltage input with sensors in 4-wire configuration and external power supply

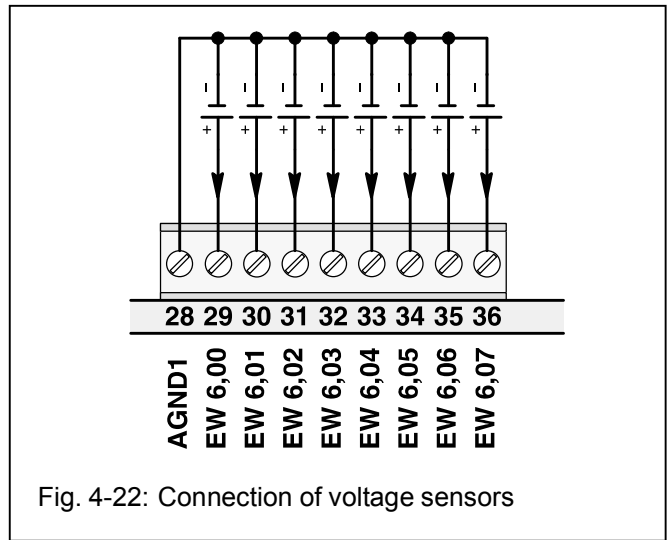

Fig. 4-22: Connection of voltage sensors

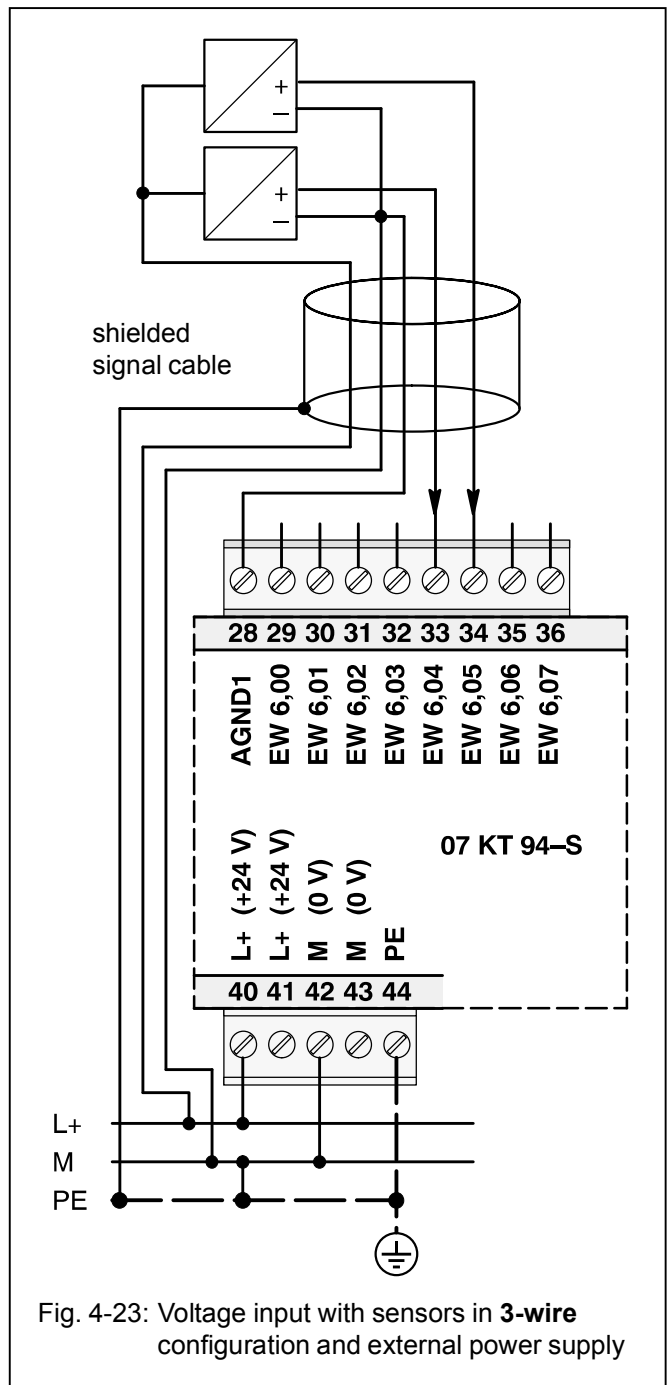

Fig. 4-23: Voltage input with sensors in 3-wire configuration and external power supply

**Measuring range 4...20 mA
(passive-type 2-pole sensors)**

Input currents that exceed the measuring range cause the overflow numerical value of +32767. If the measured value is below the range, the underflow numerical value of -32767 is set.

The input impedance is ca. 330 Ω. The current input has a self-protecting mechanism. If the input current gets too high, the shunt is switched off and the value for range overflow is generated. About every second, the unit tries to switch on the shunt again. In this way the correct measurement will succeed after the current has reached a normal value again.

The trigger of the self-protecting mechanism is displayed by the red LED Ovl as long as the overload is present. In the PLC system an error message is then stored (FK4, error number 4).

The open-circuit monitoring begins below ca. 3 mA. The value of the range underflow is stored. If the open-circuit monitoring is configured, the open-circuit event is displayed by the red LED Ovl as long as it is present. In the PLC system an error message is stored (FK4, error number 9).

The following figure shows the connection of **2-pole passive-type** analog sensors 4...20 mA.

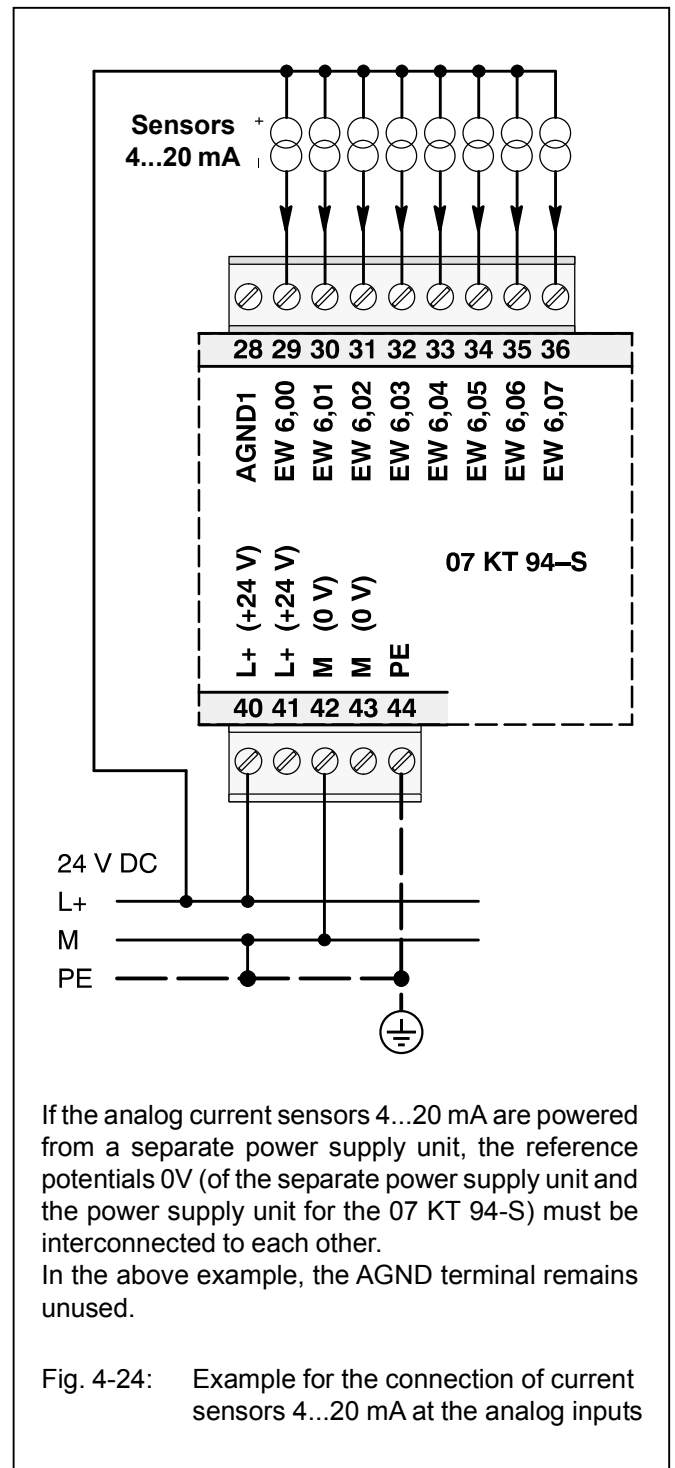

If the analog current sensors 4...20 mA are powered from a separate power supply unit, the reference potentials 0V (of the separate power supply unit and the power supply unit for the 07 KT 94-S) must be interconnected to each other. In the above example, the AGND terminal remains unused.

Fig. 4-24: Example for the connection of current sensors 4...20 mA at the analog inputs

**Measuring range 0...20 mA
(active-type sensors with external supply voltage)**

Input currents that exceed the measuring range cause the overflow numerical value of +32767. If the measured value is below the range, the underflow numerical value of -32767 is set.

The input impedance is ca. 330 Ω. The current input has a self-protecting mechanism. If the input current gets too high, the shunt is switched off and the value for range overflow is generated. About every second, the unit tries to switch on the shunt again. In this way the correct measurement will succeed after the current has reached a normal value again.

The trigger of the self-protecting mechanism is displayed by the red LED Ovl as long as the overload is present. In the PLC system an error message is then stored (FK4, error number 4).

The following figure shows the connection of a 3-wire sensor powered by 24 V DC **and** of a 2-pole sensor powered electrically isolated. Both sensors work as **active current sources** 0...20 mA.

It has to be taken into consideration, that in this application the M terminal of the basic unit 07 KT 94-S is the reference potential. AGND1 is not dimensioned for carrying the sum of the sensor currents.

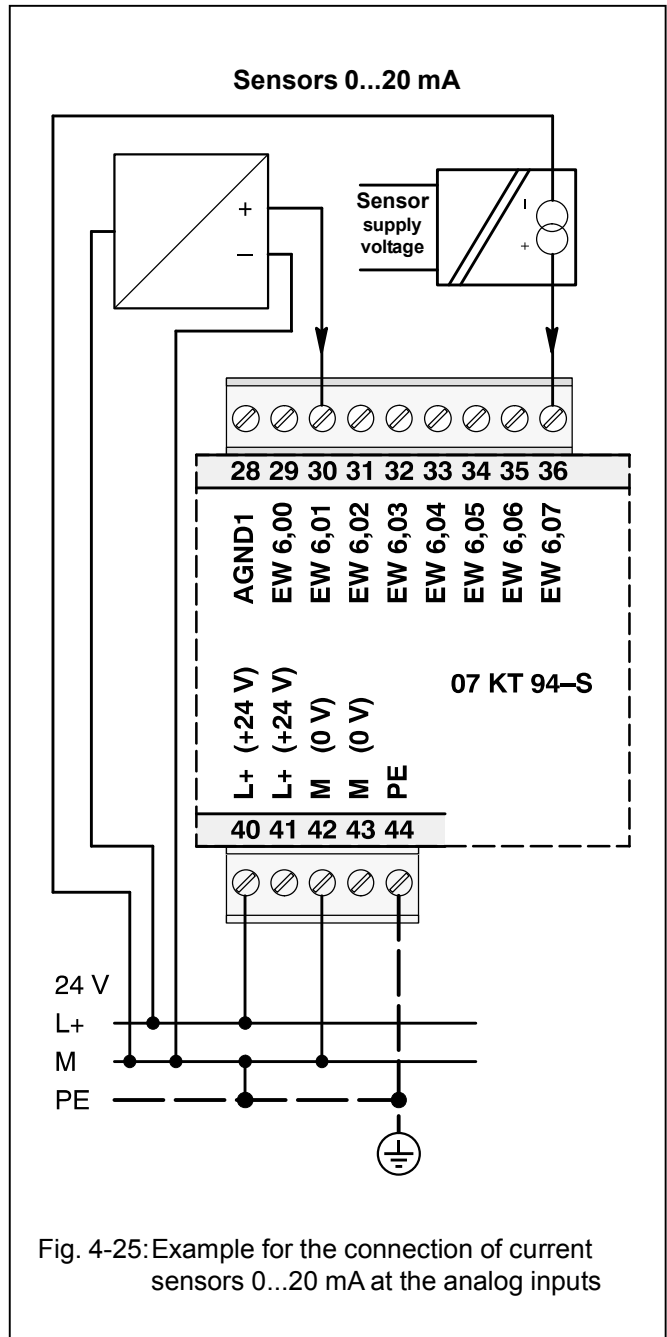

Fig. 4-25: Example for the connection of current sensors 0...20 mA at the analog inputs

Measuring ranges $\pm 10\text{ V}$ / $\pm 5\text{ V}$ / $0\dots 10\text{ V}$ / $0\dots 5\text{ V}$ as differential inputs

Differential inputs are very useful, if analog sensors are used which are remotely non-isolated (e.g. the minus terminal is remotely earthed).

Since the earthing potential is not exactly the same as AGND1, it has to be measured bipolar in order to compensate measuring errors. Additionally, in case of single-pole configuration, AGND1 would be connected directly to the remote earth potential. This would cause inadmissible (and possibly dangerous) earthing loops.

In all configurations using **differential inputs** two adjacent analog inputs belong together (e.g. EW 6,00 and EW 6,01).

For configuration, both inputs must be configured for the desired operating mode, see configuration table Fig. 4-18.

The measured value is calculated by subtraction. The value of the channel with the lower address is subtracted from the value of the channel with the higher address.

The converted measured value is available on the odd address (e.g. EW 6,01).

Important:

The common mode input voltage range equals the measuring range of the single channel. I.e. that the signals, related to AGND, at the two involved inputs must not exceed this measuring range.

Input voltages that exceed the measuring range cause the overflow numerical value of +32767. If the measured value is below the range, the underflow numerical value of -32767 is set.

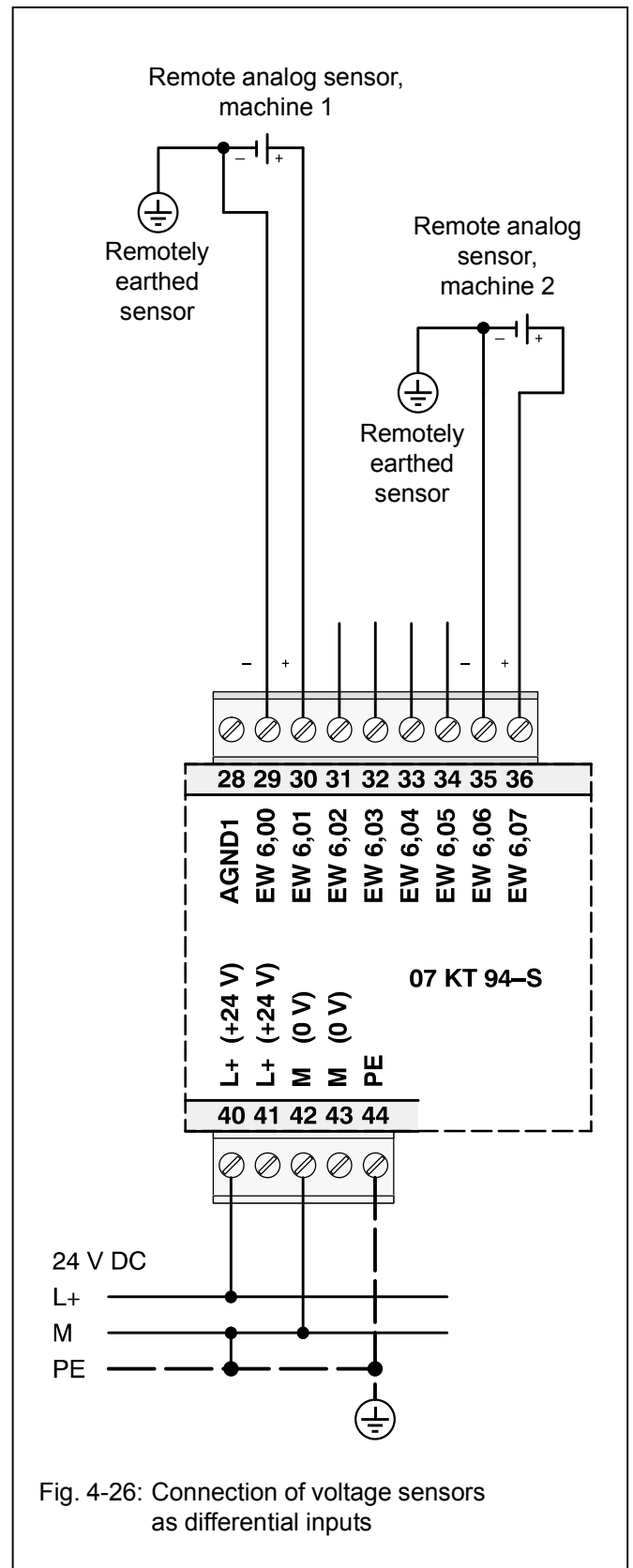

Measuring ranges $-50^{\circ}\text{C} \dots +400^{\circ}\text{C}$ and $-50^{\circ}\text{C} \dots +70^{\circ}\text{C}$ with Pt100 as temperature sensor in 2-wire configuration

When resistance thermometers are used, a constant current must flow through the measuring resistor in order to create the necessary voltage drop for the evaluation. For this purpose, the basic unit 07 KT 94-S provides a constant current sink, which is multiplexed to the 8 analog channels.

The following figure shows the connection of Pt100 resistance thermometers in **2-wire configuration**.

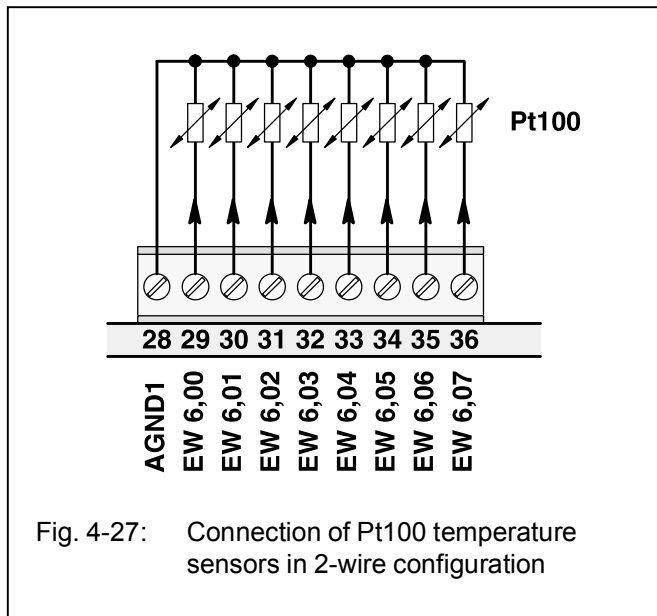

Depending on the configured operating mode, the measured value is assigned linearly as follows:

Range assigned numerical value range

$-50^{\circ}\text{C} \dots +400^{\circ}\text{C}$	$-1022 \dots +8190$ (FC02 _H ...1FFE _H)
$-50^{\circ}\text{C} \dots +70^{\circ}\text{C}$	$-1022 \dots +1433$ (FC02 _H ...0599 _H)

The 07 KT 94-S unit linearizes the Pt100 characteristic.

Temperatures that exceed the measuring range cause the overflow numerical value of +32767. If the measured value is below the range, the underflow numerical value of -32767 is set.

In case of a detected open-circuit the numerical value of +32767 is set. If the sensor is short-circuited, the numerical value of -32767 is set.

If the open-circuit or short-circuit monitoring is configured, the detected error is displayed by the red LED OvI as long as it is present. In the PLC system an error message is stored (FK4, error number 9).

In order to avoid error messages with unused analog inputs, it is useful, **not** to configure these channels for Pt100.

Measuring ranges $-50^{\circ}\text{C} \dots +400^{\circ}\text{C}$ and $-50^{\circ}\text{C} \dots +70^{\circ}\text{C}$ with Pt100 as temperature sensor in 3-wire configuration

The following figure shows the connection of Pt100 resistance thermometers in **3-wire configuration**.

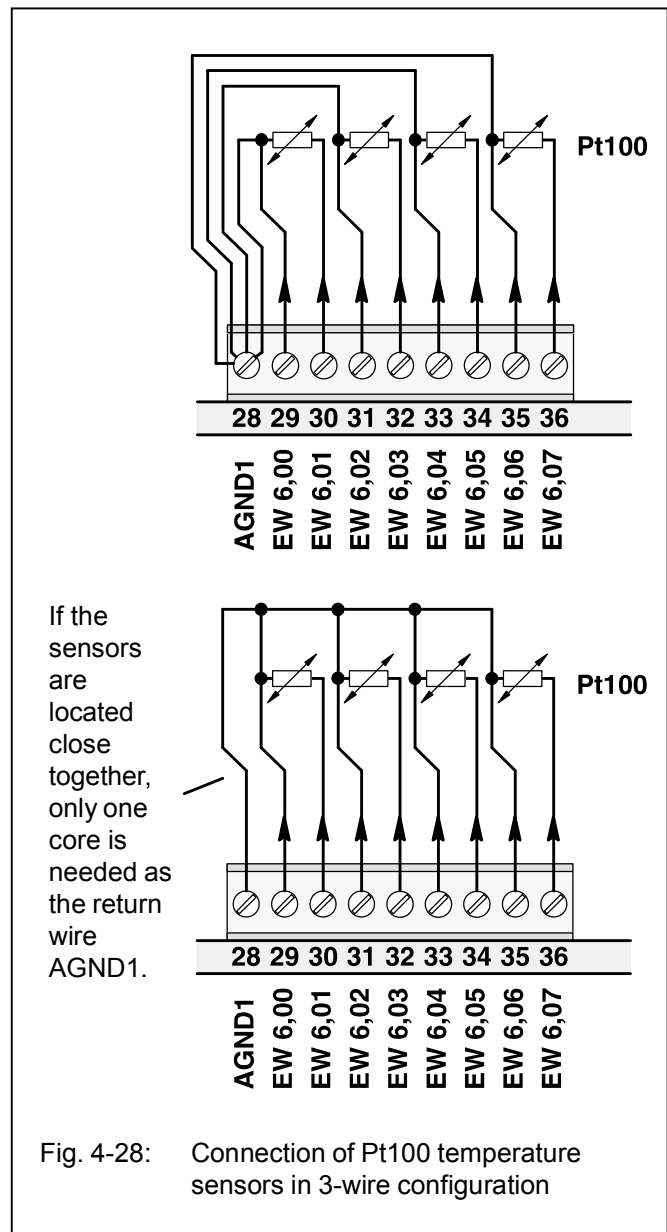

In the operating mode "**Pt100 in 3-wire configuration**" two adjacent analog inputs belong together (e.g. EW 6,00 and EW 6,01).

For configuration, both inputs must be configured to the desired operating mode, see configuration table Fig. 4-18.

The constant current of the one channel flows through the Pt100 resistance sensor, the constant current of the other channel through one of the wires.

The basic unit 07 KT 94-S calculates the measuring value from the two voltage drops and stores it under the odd address (e.g. EW 6,01).

In order to avoid measurement errors, it is absolutely necessary, to lead the cores to the Pt100 sensors in the same cable. The cores must have the same cross section. Per channel, a twisted pair is used (for the two terminals of the Pt100 sensors) plus a single core (half of a twisted pair) for the connection to AGND1.

Depending on the configured operating mode, the measured value is assigned linearly as follows:

Range	assigned numerical value range
-50 C...400°C	-1022...+8190 (FC02 _H ...1FFE _H)
-50 C...70°C	-1022...+1433 (FC02 _H ...0599 _H)

The 07 KT 94-S unit linearizes the Pt100 characteristic.

Temperatures that exceed the measuring range cause the overflow numerical value of +32767. If the measured value is below the range, the underflow numerical value of -32767 is set.

In case of a detected open-circuit the numerical value of +32767 is set. If the sensor is short-circuited, the numerical value of -32767 is set.

If the open-circuit or short-circuit monitoring is configured, the detected error is displayed by the red LED Ovl as long as it is present. In the PLC system an error message is stored (FK4, error number 9).

In order to avoid error messages with unused analog inputs, it is useful, **not** to configure this channels for Pt100.

Use of analog inputs as digital inputs

Several (or all) analog inputs can be configured as digital inputs. When doing so, they evaluate input voltages higher than ca. +7 V as signal 1. The input impedance in this operating mode is about 4 kΩ. Terminal M is the reference potential.

The input signal delay is 7 ms. It cannot be configured. The inputs are not electrically isolated.

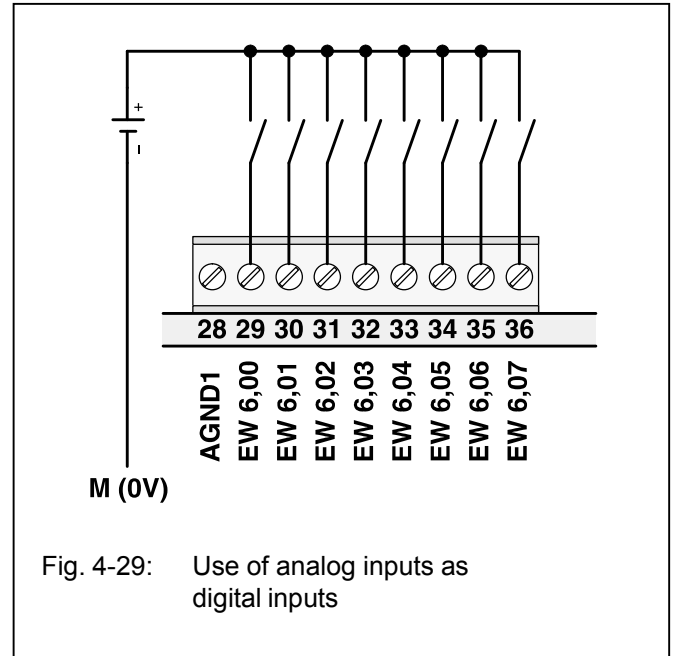
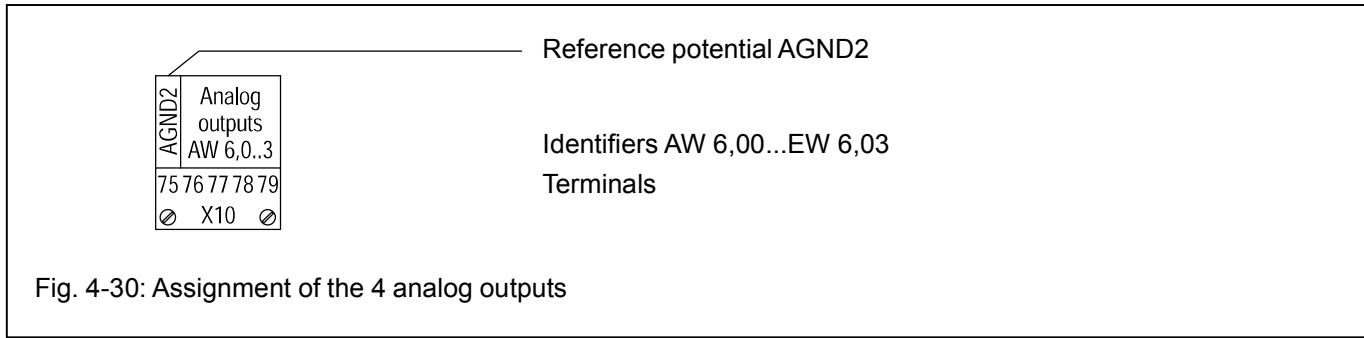

Fig. 4-29: Use of analog inputs as digital inputs

4.4.8 Connection of the 4 configurable analog outputs

The configurable analog outputs must not be used for safety-relevant applications.

The following figure shows the assignment of the 4 configurable analog outputs.



Features of the analog outputs:

- The 4 analog outputs are **not** electrically isolated.
- The resolution of the D/A converter is 12 bits.
- Analog signals are conducted in shielded cables (see Fig. 4-5).

- The analog outputs can be configured individually in a lot of different operating modes. The configuration is performed by setting certain bits in the system constants KW 88,00 to KW 88,03 as follows:

<p>The system constant</p> <p>KW 88,00 configures analog output AW 6,00 KW 88,01 configures analog output AW 6,01 KW 88,02 configures analog output AW 6,02 KW 88,03 configures analog output AW 6,03</p>	<p>Hex value in Low Byte, bits 07 06 05 04 03 02 01 00 mean:</p> <p>00_H = Analog output ±10 V (Default setting) 01_H = unused 02_H = Analog output 0...20 mA 03_H = Analog output 4...20 mA</p> <p>Hex value in High Byte, bits 15 14 13 12 11 10 09 08 mean: no meaning, reserved, may be configured with 00_H</p>
<p>Note: The (modified) system constants only become effective with the next warm or cold start.</p>	
<p>Fig. 4-31: Configuration of the 4 analog outputs</p>	

The measuring ranges of the analog outputs

Resolution in the control system:

All analog output values are converted with a resolution of 12 bits, i.e. either 11 bits plus sign or 12 bits without sign.

Examples:

Range of numerical values	Output value
-32760 _D ...0...32760 _D 8008 _H ...0000 ...7FF8 _H	-10 V...+10 V
0...32760 _D 0000...7FF8 _H	0...20 mA

Further details can be found in volume 2, chapter 5.1 "General information for the use of analog inputs and outputs".

Unused output channels may be left unconnected.

The relationship between numerical values and the output analog signals is illustrated in the following figure.

15	14	13	12	11	10	9	8	7	6	5	4	3	2	1	0
-100 %	50 %	25 %	12.5 %	6.25 %	3.13 %	1.56 %	0.78 %	0.39 %	0.20 %	0.10 %	0.05 %	0.02 %	0	0	0

Sign

±10 V	-10V	5V	2.5V	1.25V	625mV	313mV	156mV	78mV	39mV	20mV	10mV	5mV	2mV	0	0	0
0...20 mA		10mA	5mA	2.5mA	1.25mA	625µA	313µA	156µA	78µA	39µA	20µA	10µA	5µA	0	0	0
4...20 mA		8mA	4mA	2mA	1mA	500µA	250µA	125µA	62.5µA	31.3µA	16µA	8µA	4µA	+4 mA offset		
Bit values	-32768	16384	8192	4096	2048	1024	512	256	128	64	32	16	8	4	2	1

Measuring range ±10 V 11 bits resolution plus sign,
Measuring ranges 0...20 mA, 4...20 mA 12 bits resolution without sign,
 the value range of -100...+100 % corresponds to the numerical values 8008_H...7FF8_H (-32760...+32760),
 Range overflow: 7FFF_H (32767), Range underflow: 8001_H (-32767)

Fig. 4-32: Relationship between the output values and the positions of the bits in the 16-bit word

Output ranges ±10 V / 0...20 mA / 4...20 mA

In case of voltage outputs the max. output current is ±3 mA. The output is short-circuit proof.

In case of current outputs, the range of permissible output load resistors is 0...500 Ω. If in case of an error the outputs are switched off, this means the following:

Configuration ±10 V 0 V
 Configuration 0...20 mA 0 mA
 Configuration 4...20 mA 0 mA.

The relationship between the numerical values and the analog values given in figure 4-19 (analog inputs) is also valid for the analog outputs.

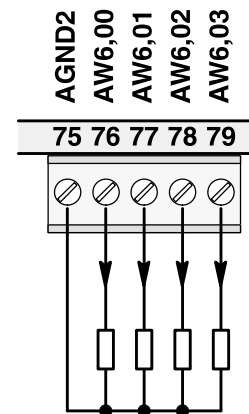

Fig. 4-33: Connection of output load resistors (for voltage or for current outputs) at the analog outputs

Circuit configuration of an analog output

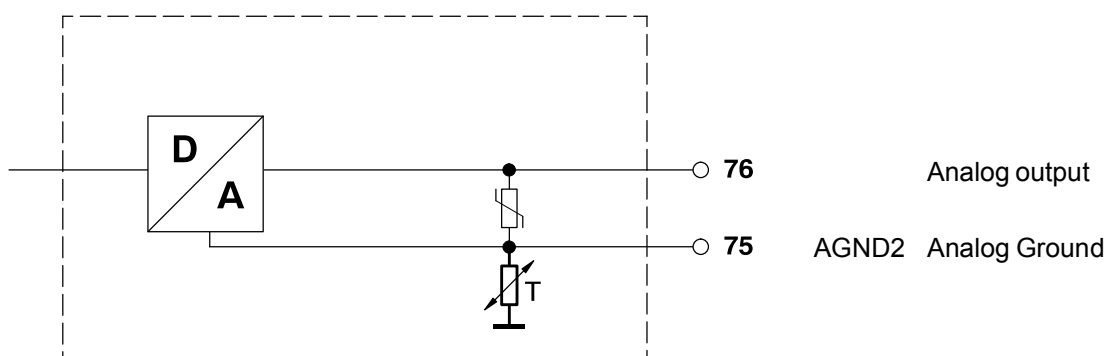
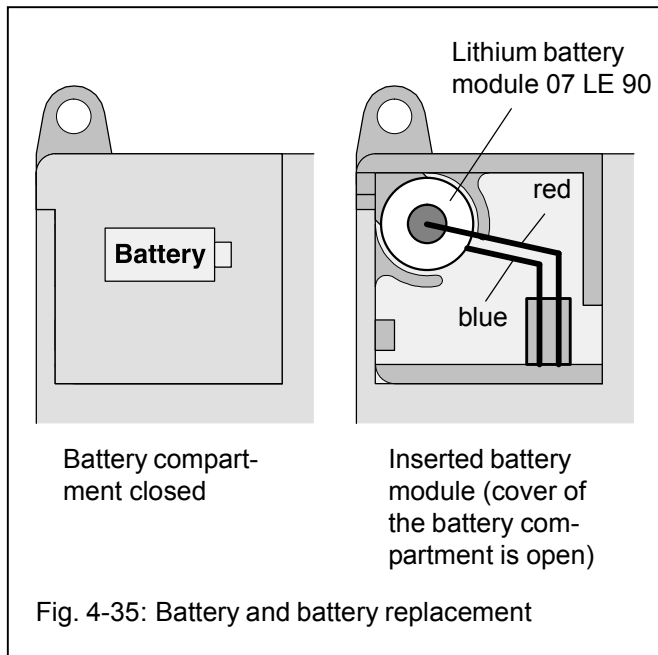

Fig. 4-34: Circuit configuration of an analog output

4.4.9 Battery and battery replacement

- The lithium battery 07 LE 90 can be inserted into the battery compartment in order to
 - backup data of user program in RAM
 - backup data of additionally in RAM contained information, e.g. flag statuses
 - backup of time and date

The battery lifetime is typ. 5 years at 25°C. The battery lifetime is the time during which the device remains operable in order to backup data while the supply voltage of the basic unit is switched off. As long as there is a supply voltage available, there is no more load on the battery other than its own leakage current.



The following handling notes have to be observed:

- Use only lithium batteries approved by ABB.
- Replace the battery by a new one at the end of its life.
- **Never short-circuit the battery!**
There is danger of overheating and explosion. Avoid accidental short-circuits, therefore do not store batteries in metallic containers or boxes and do not bring them into contact with metallic surfaces.
- **Never try to charge a battery!**
Danger of overheating and explosion.
- **Replace the battery only with the supply voltage switched on!**
Otherwise you risk data being lost.
- **Dispose of battery environmentally consciously!**
- If no battery is inserted or if the battery is exhausted, the red LED "Battery" lights up.

4.4.10 Serial interface COM1

Interface standard: EIA RS-232

Assignment of the serial interface COM1

The serial interface COM1 has the following pin assignment:

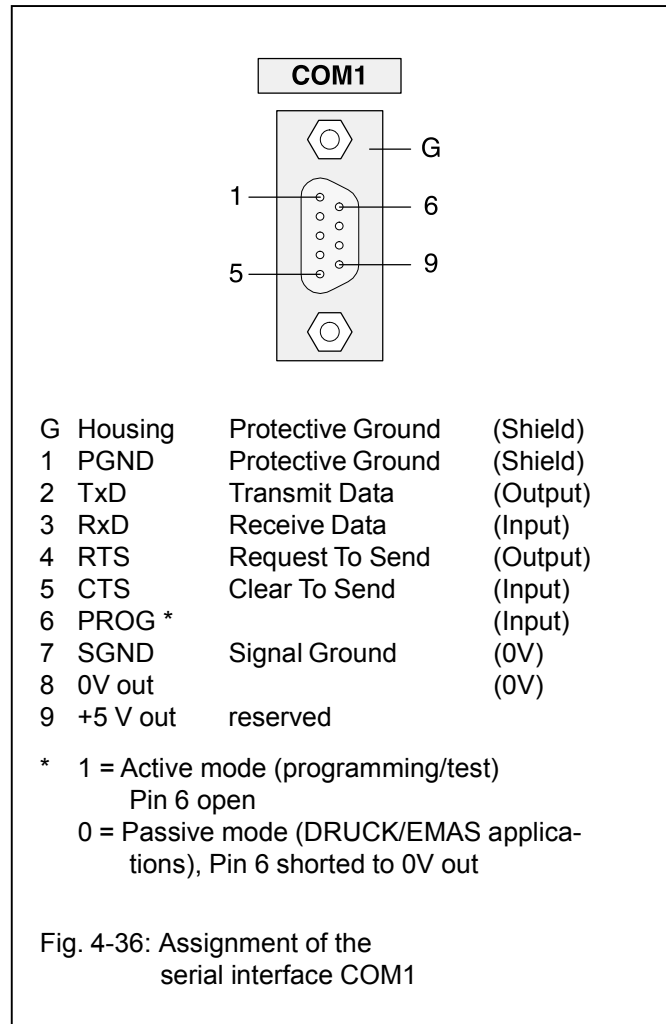

Operating modes of the serial interface COM1

Dependent on the used application

- programming and test or
 - man-machine-communication MMC
- the operating mode of the interface has to be set accordingly:

Active mode: The active mode is used for programming and testing the basic unit, i.e. it gives the user access to all the programming and test functions of the basic unit.

Passive mode: The passive mode is used to perform a communication configured with the DRUCK and EMAS blocks between the user program and a device connected to the serial interface.

Conditions for setting the operating modes of the interface COM1

RUN/STOP switch	System constant KW00,06	System cable/device	Mode set by this
STOP	x	x	Aktive
RUN	1	x	Aktive
RUN	2	x	Passive
RUN	0, <0, >2	07 SK 90	Aktive
RUN	0, <0, >2	07 SK 91	Passive

x: without effect

Temporary interruption of the passive mode

While a communication between the DRUCK or EMAS blocks and a device connected to COM1 is being executed, it may be come necessary to modify the program, for example. For this purpose, you must switch over COM1 from the passive mode into the active mode.

Switch-over: Passive mode → Active mode

There are three possibilities for switching over:

- Set the RUN/STOP switch to the "STOP" position
- Replace the cable 07 SK 91 by cable 07 SK 90 (if KW 00,06 is set to <0 or >2)
- Send the following special command to the PLC:

The latter option has the advantage that the switch-over can also be controlled remotely, e.g. via telephone line and suitable dial-up modems. The ASCII character has the decimal code of 127 and the hexadecimal code of 7F_H. You can generate this character by simultaneously pressing the control key <CTRL> and the delete key <->.

Notes:

On German keyboards the control key is labelled by <Strg> instead of <CTRL>.

If the switch-over to the active mode was performed using the special command , please observe the following:

During the execution of the PLC program, the system constant KW 00,06 must **not** be sent to the PLC because this would cause the system to be switched back to the passive mode.

The special command assigns the value of "1" to the image of the system constant KW 00,06 located in the operand memory. The PLC evaluates the value of this image and sets the application mode of COM1 correspondingly.

Switching back: Active mode → Passive mode

There are three possibilities for switching back:

- Return RUN/STOP switch to the "RUN" position
- Replace cable 07 SK 90 by cable 07 SK 91 again
- Cancel the special command as follows:
 - If the PLC program is in the "aborted" condition:

Start the PLC program.
 - If the PLC program is in the "running" condition:

Send the original value of the system constant KW 00,06 to the PLC again (907 PC 33 menu item "Send constants")

or

overwrite the system constant KW 00,06 by the original value (907 PC 33 menu item "Overwriting")

Interface parameters

Active mode: The settings of the interface parameters cannot be changed.

Data bits:	8
Stop bits:	1
Parity bits:	none
Baud rate:	9600
Synchronization:	RTS/CTS

Passive mode: Default setting

Synchronization:	RTS/CTS
Interface identifier COM1:	1
Baud rate:	9600
Stop bits:	1
Data bits:	8
Parity bits:	none
Echo:	off
Send Break Character:	0
Enabling End-of-text character for sending direction:	no 1)
Sending End-of-text character:	<CR> 1)
Receiving End-of-text character:	<CR> 2)

1) The default End-of-text character for the sending direction (CR) is not sent. Nevertheless, this default End-of-text character (CR) must not appear in the message of the assigned DRUCK block.

2) For the direction of reception, an End-of-text character is always necessary. This default End-of-text character (CR) must not appear neither in the message text nor in the user data of the assigned EMAS block.

For the passive mode of COM1, the interface parameters can be changed using the SINIT function block. If the changed values are not plausible, the COM1 interface uses the default values.

The interface is newly initialized each time the operating mode is switched over.

The active mode parameters are set in the active mode, whereas in the passive mode the parameters established by the SINIT block or the default values are set.

4.4.11 Serial interface COM2

Interface standard: EIA RS-232

Assignment of the serial interface COM2

The serial interface COM2 has the following pin assignment:

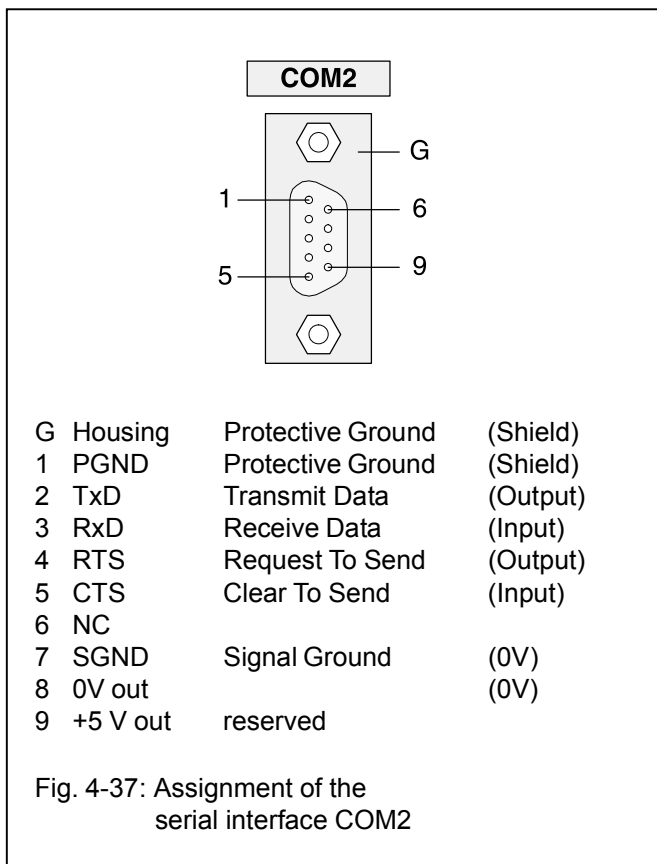

Operating modes of the serial interface COM2

The serial interface COM2 is only suitable for the passive mode. In addition, it can be operated as a MODBUS interface.

The passive mode is used to perform a communication configured with the DRUCK and EMAS blocks between the user program and a device connected to the serial interface.

The application-specific initialization of COM2 can be performed using the SINIT function block.

Interface parameters

Passive mode: Default setting

Synchronization:	RTS/CTS
Interface identifier COM1:	1
Baud rate:	9600
Stop bits:	1
Data bits:	8
Parity bits:	none
Echo:	off
Send Break Character:	0
Enabling End-of-text character for sending direction:	no 1)
Sending End-of-text character:	<CR> 1)
Receiving End-of-text character:	<CR> 2)

1) The default End-of-text character for the sending direction (CR) is not sent. Nevertheless, this default End-of-text character (CR) must not appear in the message of the assigned DRUCK block.

2) For the direction of reception, an End-of-text character is always necessary. This default End-of-text character (CR) must not appear neither in the message text nor in the user data of the assigned EMAS block.

For the passive mode of COM2, the interface parameters can be changed using the SINIT function block. If the changed values are not plausible, the COM2 interface uses the default values.

In the passive mode the parameters established by the SINIT block or the default values are set.

4.4.12 Networking interface

It is not allowed to send or to receive safety-relevant data via the networking interface.

The 07 KT 94-S basic unit is equipped with a special parallel interface. It is thus possible to network it with another bus system using an additional communication processor module.

The additional communication processor has its own housing. Both housings (of the 07 KT 94-S and of the communication processor) are assembled by means of a snap-on connection.

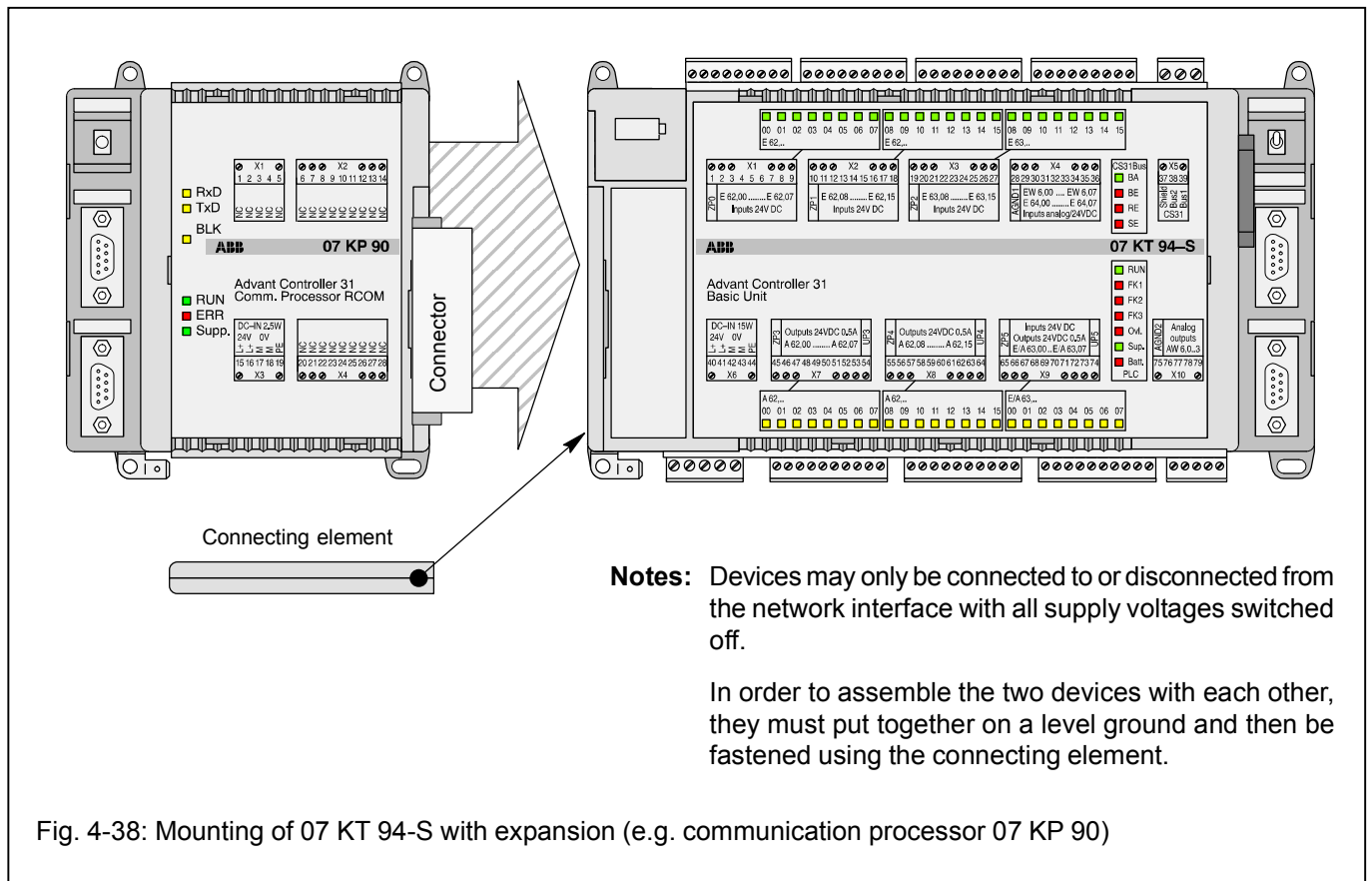

Fig. 4-38: Mounting of 07 KT 94-S with expansion (e.g. communication processor 07 KP 90)

4.5 SmartMedia Card

The SmartMedia Card serves for storing data up to 2 MB not being lost over an power OFF/ON cycle. It is used in the 07 KT 94-S basic unit. It is recommended only to use ABB-proven SmartMedia Cards.

4.5.1 Field of application

- Storing and loading of PLC programs
 - one separate SmartMedia Card is used for each user program.
- Storing and loading of user data
 - there are 250 data segments with 128 blocks each available (1 block = 32 words).
- Loading of firmware updates

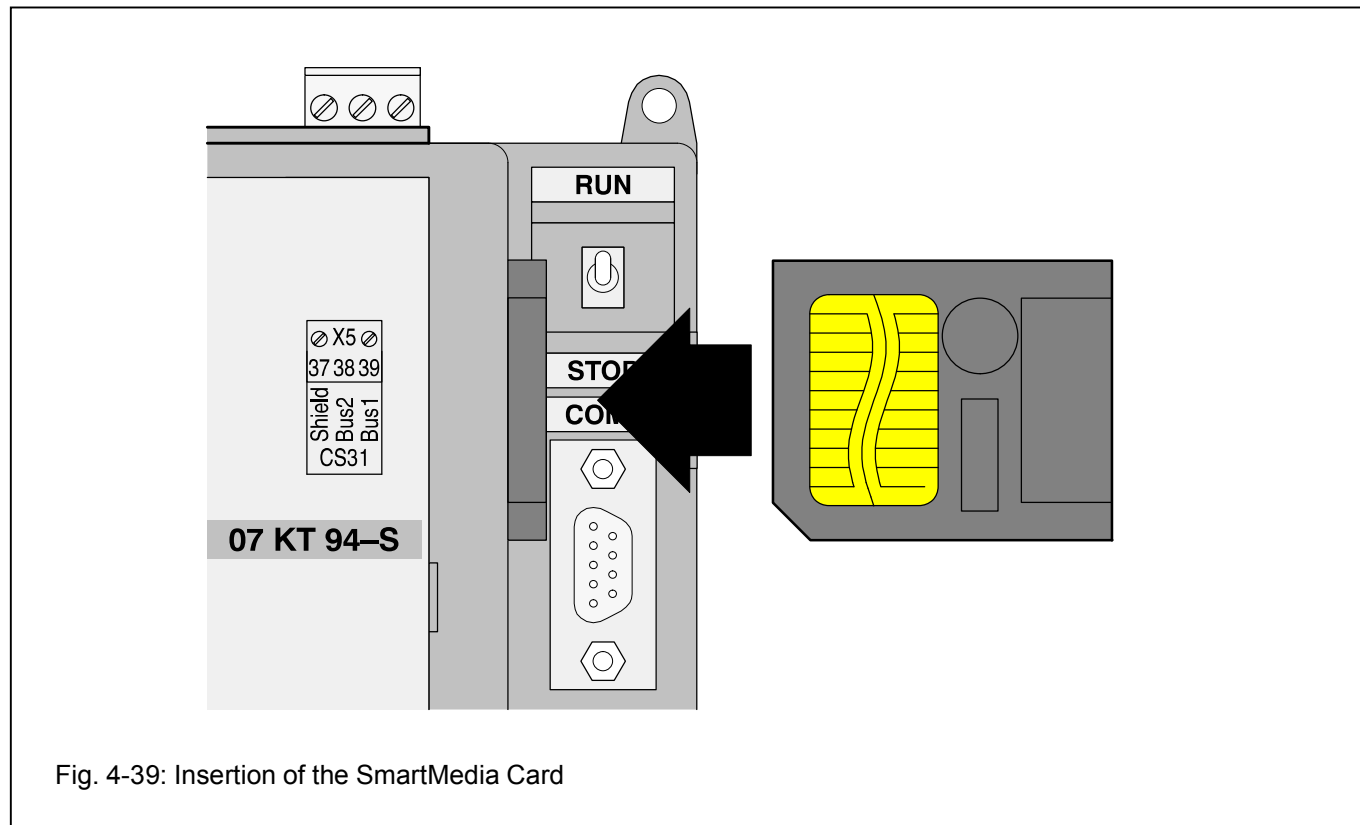

Fig. 4-39: Insertion of the SmartMedia Card

4.5.2 Handling instructions

- The SmartMedia Card is inserted with the contact field visible (see the figure above).
- A SmartMedia Card, once initialized as user data memory, can no more be used as a user program card (for initialization see "Operating and test functions", volume 7 of the AC31 system description).
- The SmartMedia Card must be protected from
 - mechanical stress (e.g. do not bend)
 - electrostatic discharge
 - contact pollution (do not touch the contacts)

4.5.3 Access

- Access to the SmartMedia Card is possible via the programming interface with the aid of the operating and test functions, see volume 7 of the AC31 system description, chapter 2.4, commands FCINIT, FCWR, FCRD, FCDEL, SP.
- Access within the PLC program is possible with CEs, see the documentation of the programming software, the CEs are FCWR, FCRD, FCDEL.

4.5.4 How to store a user program in the SmartMedia Card

In order to save the user program in the SmartMedia Card (SMC Card), a brand new SMC Card is required or another one which has never been initialized as a user data memory.

Sequence of program saving

1. Load PLC user program into the PLC (RAM)
2. While power is ON, insert the SMC Card
3. Activate monitor command "SP".

The user program is now copied from the PLC's RAM to its Flash EPROM and then loaded into the SMC Card.

An update of the 07 KT 94-S's operating system (firmware) is not possible with the SMC Card.

4.5.5 How to load the user program from the SmartMedia Card

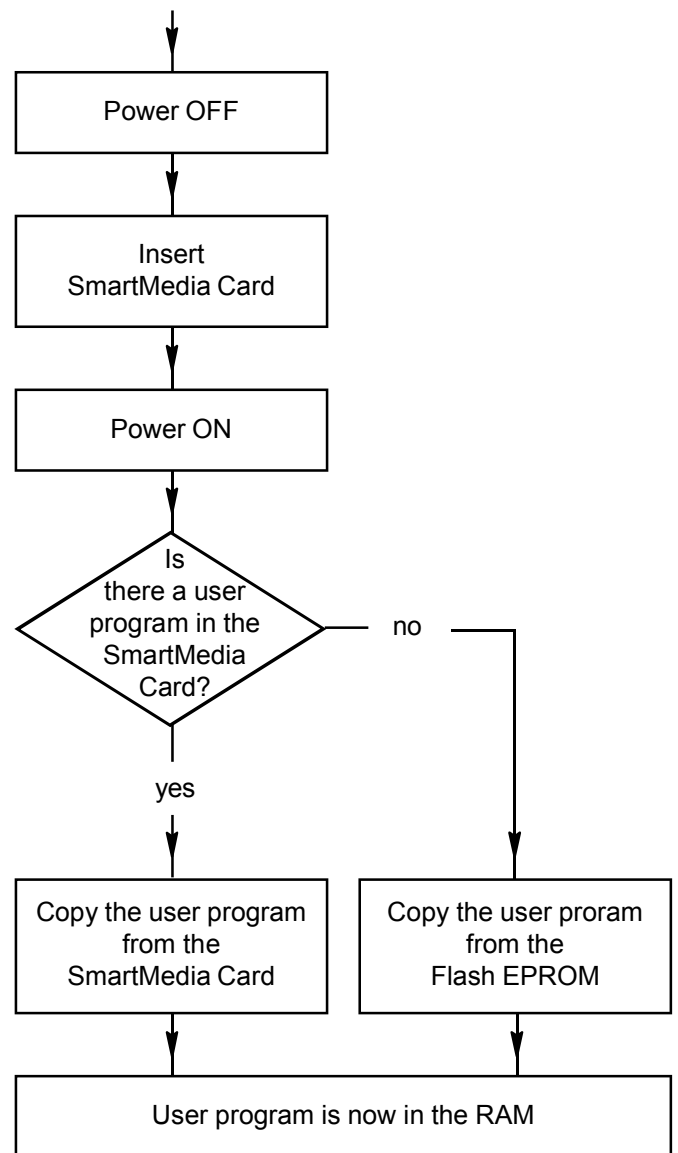

The user program is copied from the SmartMedia Card (or from the Flash EPROM) to the RAM with all of the following actions:

- Power ON
- Cold start or warm start
- RUN/STOP switch toggled to RUN
- GO

With all these actions, the SmartMedia Card has the higher priority. If the card is inserted, its program is used rather than that from the Flash EPROM.

4.6 High-speed counter

Features

The high-speed counter used in the basic unit 07 KT 94-S works independently of the user program and is therefore able to respond quickly to external signals. It can be used in seven different and configurable operating modes.

The desired operating mode is set in the system constant KW 85,02 (described later). The configured operating mode is only activated during initialization (power-on, cold start, warm start). For all operating modes, the same function block **COUNTW** is used.

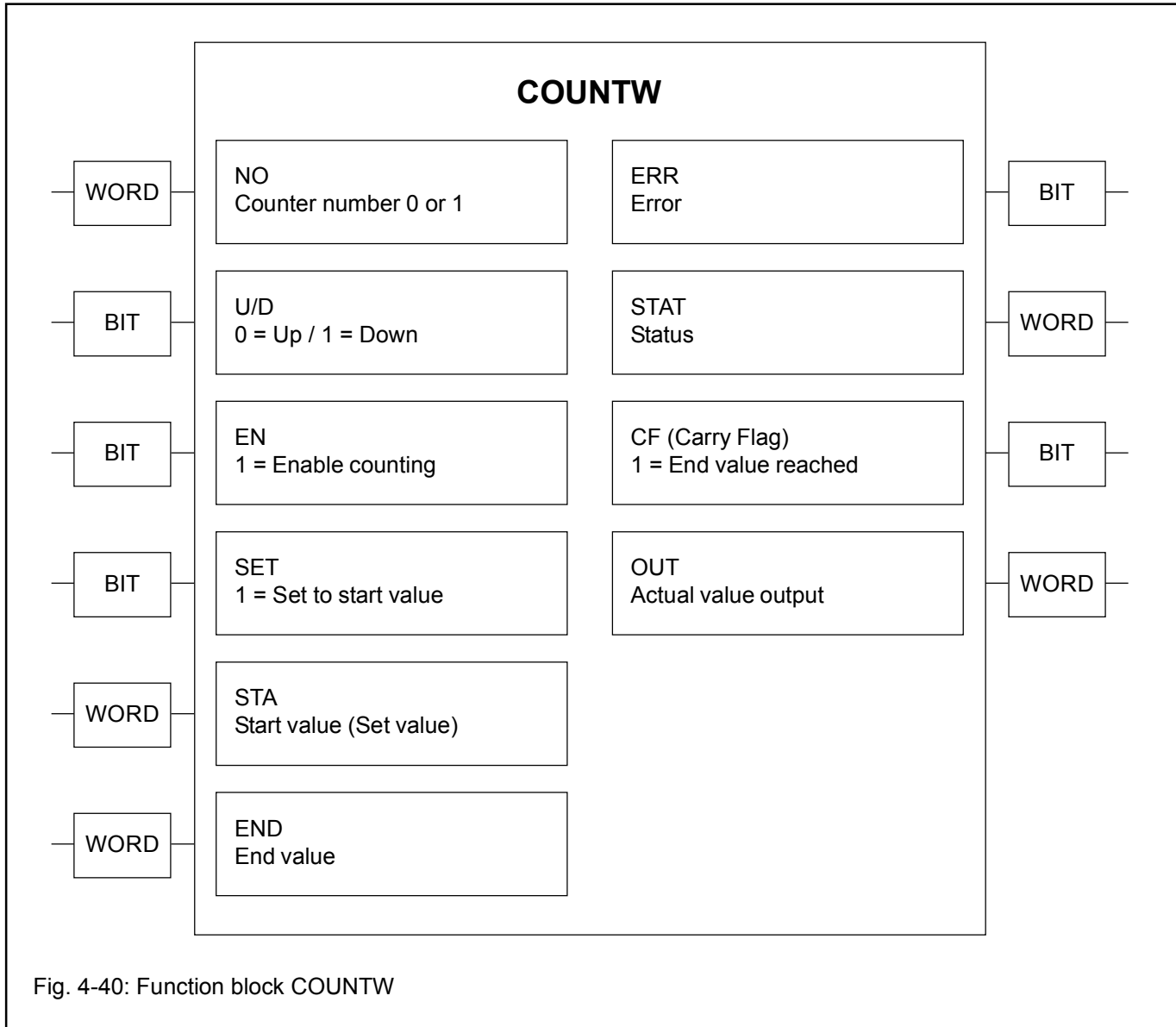
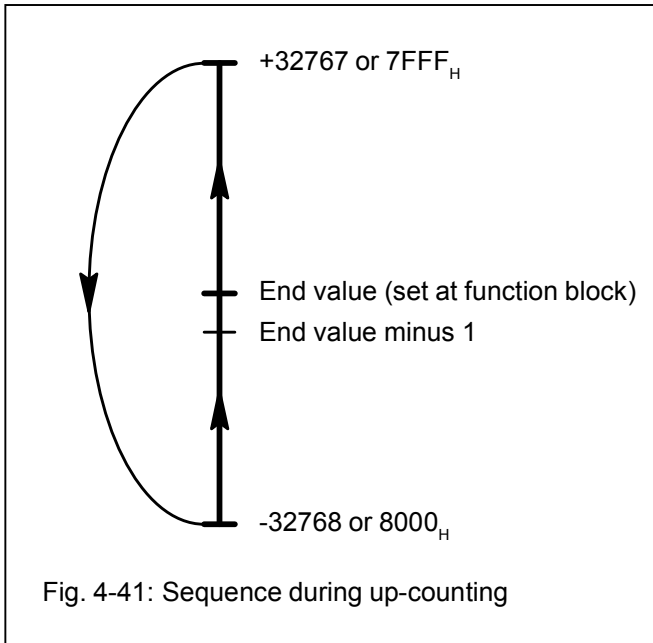

Fig. 4-40: Function block COUNTW

Independent of the selected operating mode, the following features are valid:

- The pulses at the counter input or the evaluated signals at tracks A and B in case of connection of incremental position sensors are counted.
- The maximum counting frequency is 50 kHz.
- The counter uses the terminals 2 (E 62,00) and 3 (E 62,01) as fast inputs and, in one operating mode, also the output terminal 46 (A 62,00). In order to make all binary inputs and outputs available for other purposes than counting, it is possible, to disable the 07 KT 94-S's counting function.
- The counter can count upwards in all operating modes. It counts beginning at the start value (set value) up to the end value (max. from -32768 to $+32767$ or from 8000_H to $7FFF_H$). After reaching $+32767$, the counter jumps with the next pulse to -32768 . When the counter reaches the end value **END**, which was set in the function block, the value **CF=1** is stored in the function block. Only when the counter is set again (**SET**), **CF** is reset to 0.

- Sequence of the up-counting procedure:



- In some operating modes, the counter can count downwards, too. If this is wanted, the input U/D (Up/Down) of the function block must be configured to 1. When doing so, the counter starts counting at the start value (set value) down to the end value (max. from +32767 to -32768 or from 7FFF_H to 8000_H). After reaching -32768, the counter jumps with the next pulse to +32767. When the counter reaches the end value END, which was set in the function block, the value CF=1 is stored in the function block. Only when the counter is set again (SET), CF is reset to 0.
- Sequence of the down-counting procedure:

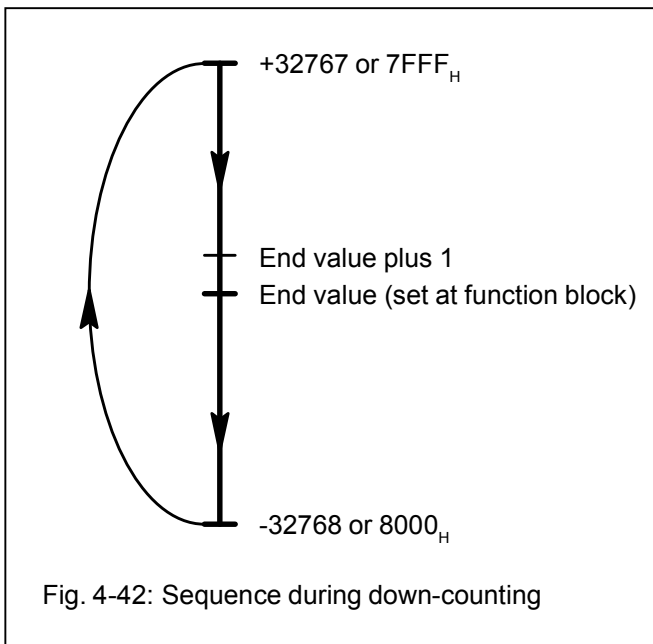

- Enabling of the counting signals:

The counting signals must be enabled. This is done depending on the operating mode either via a terminal or with the input EN (Enable) of the function block.

- Setting the counter to a start value:

The counter can be set to a start value. This value must be present at the input STA (Start value) of the function block. Using the set signal (dependent on the operating mode either via a terminal or with the SET input of the function block) the value of the word variable at STA is written into the counter.

Note: If the SET and EN signals are present during several processing cycles, the processor sets the counter every program end crossing anew. During the rest of the processing cycle the counter counts pulses.

- Reading the counter content:

The current counter content (actual value) can always be read at the OUT output (actual value output) of the function block.

- Configuring the counter number:

There are operating modes, where two counters can work independently of each other. Only in this case, the function block is used twice in the program. The first function block is assigned with 0 at input NO (Counter number) and the second function block is assigned with 1 at NO. In other operating modes, NO is assigned with 0.

- Error bit:

The function block bit output ERR=1 shows, that the STAT (status) output word contains an error code.

- Meaning of the error code in STAT:

The output word in STAT (status) has the following meaning:

- 1...255 = selected operating mode in KW 85,02
- 256 = no operating mode selected (KW 85,02 = 0)
- 257 = operating mode in KW 85,02 is unknown or forbidden

In the following, it is described, which operating modes can be configured, how to do it and what differences they have.

The configurable operating modes:

<p>The system constant</p> <p>KW 85,02 configures the operating mode of the counter</p>	<p>Hex value in Low Byte, bits 07 07 05 04 03 02 01 00 mean:</p> <p>00_H = No counter (default setting) 01_H = Mode 1, one up-counter 02_H = Mode 2, one op-counter with enable input 03_H = Mode 3, two up/down counters 04_H = Mode 4, two up/down counters, at the second counter the falling edges are counted 05_H = Mode 5, one up/down counter, the set input is edge-triggered (rising edge) 06_H = Mode 6, one up/down counter, the set input is edge-triggered (falling edge) 07_H = Mode 7, one up/down counter for position sensors</p> <p>The High Byte is configured with 00_H.</p>
<p>Note: The (modified) system constants only become effective with the next warm or cold start.</p>	
<p>Fig. 4-43: Configuration of the counter's operating modes</p>	

- Operating mode 0: **No counter**

If the integrated high-speed counter is not used, this setting is selected. All binary inputs and outputs are available for other purposes.

- Operating mode 1: **1 up-counter**

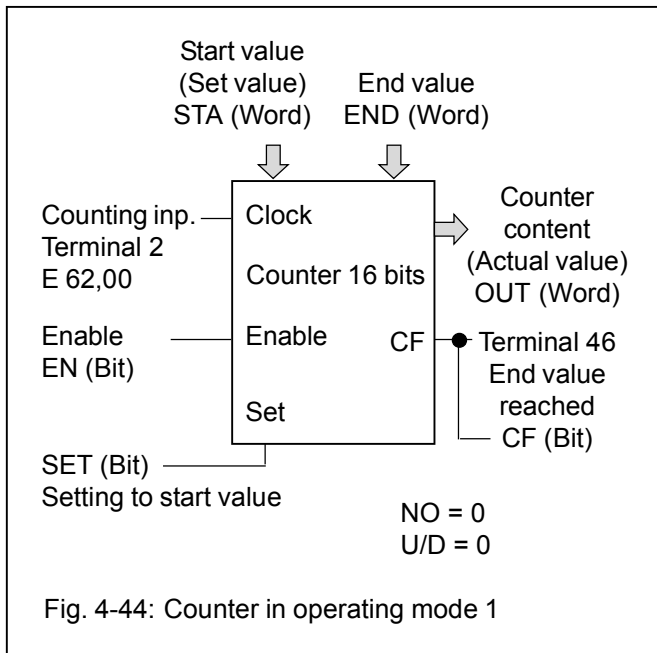

The following two terminals are reserved for the counter and cannot be used for other purposes:

- Terminal 2 (E62,00): Counting input
- Terminal 46 (A62,00): Output "End value reached"

Enabling of the counting input and of the output "End value reached" is performed via the function block with EN=1.

- Operating mode 2: **1 up-counter with enable input as terminal**

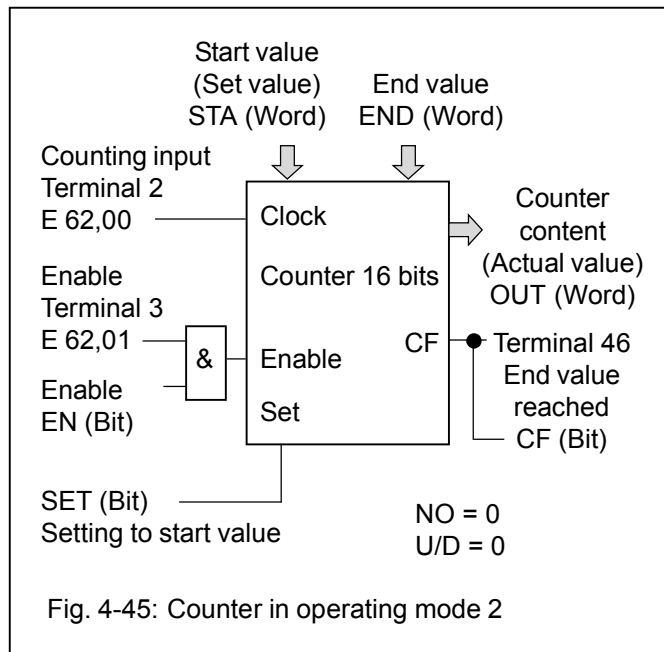

The following three terminals are reserved for the counter and cannot be used for other purposes:

- Terminal 2 (E62,00): Counting input
- Terminal 3 (E62,01): Enable input
- Terminal 46 (A62,00): Output "End value reached"

The enable input enables the counting input as well as the output "End value reached".

The counter is only enabled if the enabling input E 62,01 = 1 and at the function block the input EN = 1.

- Operating mode 3: **2 up/down counters**

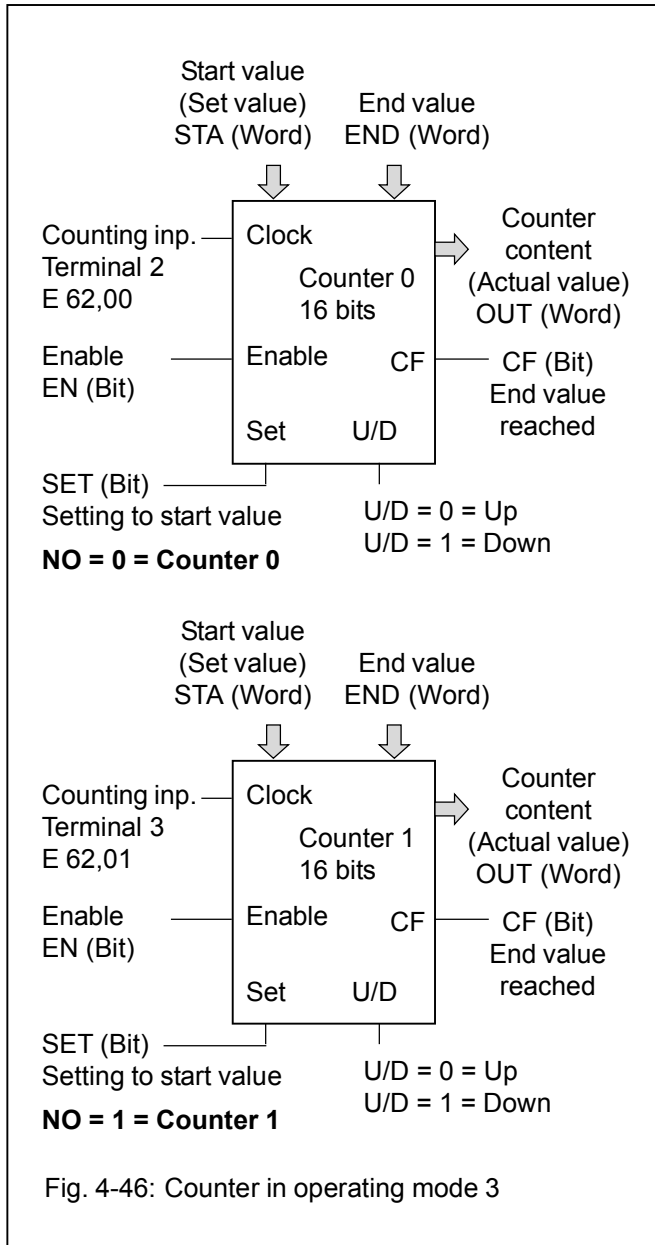

In this operating mode exist two counters which work independently of each other. The signal "End value reached" can only be read from the function blocks, not via terminals.

The following two terminals are reserved for the counters and cannot be used for other purposes:

Terminal 2 (E62,00): Counting input of counter 0
Terminal 3 (E62,01): Counting input of counter 1

The COUNTW function block is needed twice.

Note:

It is not intended to change the counting direction (with U/D) while the counter is running. When U/D is changed, this forces that the counter is set to its start value. After that, the counter starts counting in the new direction.

- Operating mode 4: **2 counters (1 counting input is inverted)**

This operating mode equals operating mode 3 with the only exception, that the second counting input (counter 1) is inverted. It counts the falling edges at terminal 3 (E 62,01).

- Operating mode 5: **1 up/down counter with an edge-triggered set input via terminal**

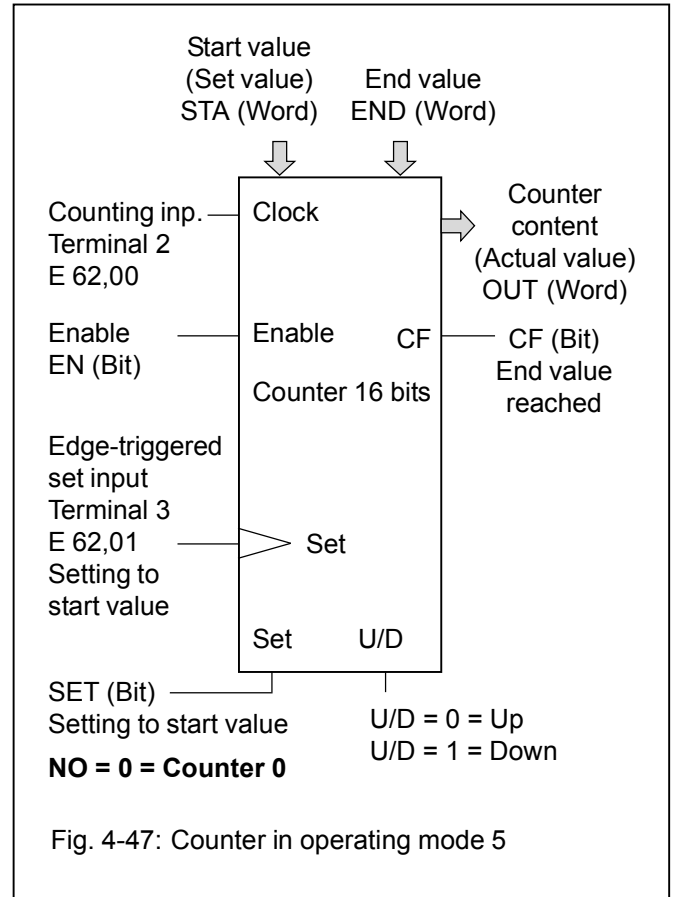

In this operating mode, an up/down counter with an edge-triggered set input is available. Edge-triggered means that the set function is effective only on the signal edge and not during the time the signal is high.

The following two terminals are reserved for the counters and cannot be used for other purposes:

Terminal 2 (E62,00): Counting input
Terminal 3 (E62,01): Edge-triggered set input

The edge-triggered set input is in effect on the rising edge at terminal 3.

The signal "End value reached" can only be read from the function block, not via a terminal.

Note:

It is not intended to change the counting direction (with U/D) while the counter is running. When U/D is changed, this forces that the counter is set to its start value. After that, the counter starts counting in the new direction.

- Operating mode 6:
1 up/down counter with edge-triggered set input via terminal

This operating mode equals operating mode 5 with the only exception, that the edge-triggered set input is in effect on the falling edge.

- Operating mode 7:
Counter for incremental position sensors

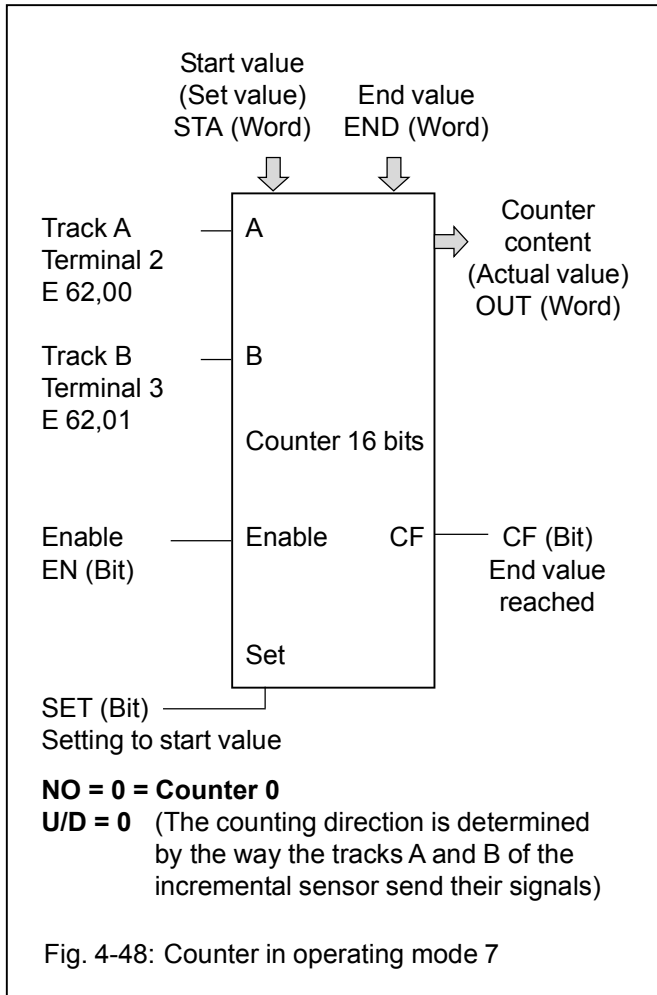

In this operating mode, incremental position sensors can be used which give their counting signals on tracks A and B in a 90° phase sequence to each other. Dependent on the sequence of the signals at A and B the counter counts up or down. The module has no pulse multiplier (such as x2 or x4).

Only sensors which output 24 V signals can be used. 5 V signals must be converted into 24 V signals. A zero track cannot be connected.

The signal "End value reached" can only be read from the function block, not via a terminal.

The following two terminals are reserved for the counter and cannot be used for other purposes:

- Terminal 2 (E62,00): Track A of the position sensor
- Terminal 3 (E62,01): Track B of the position sensor

4.7 Technical Data 07 KT 94-S

In general, the technical system data listed under "System data and system configuration" in chapter 1 of volume 2 of the Advant Controller 31 system description are valid. Additional data or data which are different from the system data are listed as follows.

4.7.1 General data

Number of digital inputs	24
Number of digital transistor outputs	16
Number of digital inputs/outputs	8
Number of analog inputs	8
Number of analog outputs	4
I/O expansion via CS31 system bus by up to	992 digital inputs 992 digital outputs 224 analog input channels 224 analog output channels max. 31 remote modules altogether
Number of serial interfaces	2 (for programming or connection to man-machine communication)
Number of parallel interfaces	1 special interface for connection of a communication processor (for networking with other bus systems)
Integrated memory	Flash EPROM 512 kB (240 kB program + 120 kB user data) RAM 2 MB (240 kB program with on-line programming)
Resolution of the integrated real-time clock	1 second
Data of the integrated high-speed hardware counter	
Number of operating modes	7
Counting range	-32768...+32767 (16 bits signed integer)
Counting frequency	max. 50 kHz
Processing time, 65 % bits, 35 % words	typ. 0.3 ms/kB program
Number of software timers	any (max. 80 simultaneously active)
delay time of the timers	1 ms...24.8 days
Number of up/down counter software blocks	any
Number of bit flags	8192
Number of word flags	8192
Number of double word flags	1024
Number of step chains	256
Number of constants KW	1440
Number of constants KD	384
Diagnosis	Cycle time monitoring, battery monitoring, detection of syntax errors and checksum monitoring
Indication of operating statuses and errors	60 LEDs altogether
Wiring method	removable screw-type terminal blocks
Power supply, CS31 system bus	max. 1 x 2.5 mm ² or max. 2 x 1.5 mm ² (see also page 4-9)
all other terminals	max. 1 x 1.5 mm ²
4.7.2 Power supply	
Rated supply voltage	24 V DC
Current consumption	max. 0.35 A
Protection against reversed polarity	yes

4.7.3 Lithium battery

Battery for backup of RAM contents

Battery module 07 LE 90

Lifetime at 25°C

typ. 5 years

4.7.4 Digital inputs

Number of channels per module

24

Distribution of channels into groups

3 groups of 8 channels each

Common reference potential

for group 1 (8 channels)

ZP0 (channels 62,00...62,07)

for group 2 (8 channels)

ZP1 (channels 62,08...62,15)

for group 3 (8 channels)

ZP2 (channels 63,08...63,15)

Electrical isolation

between the groups,
between groups and other circuitry
(see also Fig. 4-4)

Signal coupling of input signals

with optocoupler

Configuration possibilities of the inputs

Input signal delay

typ. 7 ms (configurable to 1 ms)

Channels E 62,00 and 62,01

configurable for the high-speed counter

Signalling of input statuses

one green LED per channel,
the LEDs correspond functionally to the input signals

Input signal voltage

Signal 0

-30 V...+ 5 V

Signal 1

+13 V...+ 30 V

Input current per channel

Input voltage = +24 V

typ. 7.0 mA

Input voltage = + 5 V

> 0.2 mA

Input voltage = +13 V

> 2.0 mA

Input voltage = +30 V

< 9.0 mA

Max. cable length, unshielded

600 m

Max. cable length, shielded

1000 m

4.7.5 Digital outputs

Number of channels per module

16 transistor outputs

Distribution of channels into groups

2 groups of 8 channels each

Common supply voltage

for group 1

UP3 (channels 62,00...62,07)

for group 2

UP4 (channels 62,08...62,15)

Electrical isolation

between the groups,
between groups and other circuitry
(see also Fig. 4-4)

Signalling of output statuses

one yellow LED per channel,
the LEDs correspond functionally to the output signals

Output current

Rated value

500 mA with UP3/4 = 24 V

Maximum value

625 mA with UP3/4 = 24 V + 25%

Leakage current with signal 0

< 0.5 mA

Demagnetization of inductive loads

internally with a varistor

Switching frequency with inductive loads

max. 0.5 Hz

Switching frequency with lamp loads

max. 11 Hz with max. 5 W

Max. cable length	400 m (pay attention to voltage drops)
Short-circuit proof / overload proof	yes
Protection of the outputs against reversed polarity	yes
Forcing of 24 V DC at the outputs possible	yes
Total load (via UP3 or UP4)	max. 4 A
4.7.6 Digital inputs/outputs	
Number of channels per module	8 inputs/outputs
Distribution of channels into groups	1 group with 8 channels
Common reference potential	ZP5 (channels E/A 63,00...E/A 63,07)
Common voltage supply	UP5 (channels E/A 63,00...E/A 63,07)
Electrical isolation	between the group and the other circuitry (see Fig. 4-4)
Signal coupling of the input signals	with optocoupler
Configuration possibilities of the inputs	
Input signal delay, channels E 63,00...E 63,07	typ. 7 ms (configurable to 1 ms)
Signalling of input/output statuses	one yellow LED per channel, the LEDs correspond functionally to the I/O signals
Input signal voltage (if used as inputs)	for details see Fig. 4-16 as well as the chapter "Circuit configuration of the digital inputs/outputs"
Signal 0	-6 V...+ 5 V
Signal 1	+13 V...+ 30 V
Input current per channel	see Digital inputs
Output current / switching frequency / inductive loads	see Digital outputs
Max. cable length	see Digital inputs/outputs
4.7.7 Analog inputs	
Number of channels per module	8
Distribution of channels into groups	1 group with 8 channels
Common reference potential for group 1 (8 channels)	AGND1 (channels 06,00...06,07)
Electrical isolation	none (see also Fig. 4-4).
Max. permissible potential difference between Terminal M (minus pole of the power supply voltage) and terminal AGND (analog I/O minus pole)	± 1 V
Signalling of input statuses	none
Configuration possibilities (each channel), see 4.4.7	0...10 V, 0...5 V, ±10 V, ±5 V (also with differential signal) 0...20 mA, 4...20 mA Pt100 -50...+400°C and -50...+70°C (2-wire and 3-wire configuration) digital input
Input impedance per channel,	
voltage input	> 100 kΩ
current input	ca. 330 Ω
digital input	ca. 4 kΩ

The current input has a self-protecting mechanism. If the input current gets too high, the shunt is switched off and the value for range overflow is generated. About every second, the unit tries to switch on the shunt again. In this way the correct measurement will succeed after the current has reached a normal value again.

Time constant of the input filter	470 μ s with voltage, 100 μ s with current
Conversion cycle of current and voltage channels	Each configured input channel (U, I, Pt100) increases the conversion cycle of the U/I channels by typ. 1 ms.
Conversion cycle (by filtering time) of Pt100 channels	Each configured input channel (U, I, Pt100) increases the conversion cycle of the Pt100 channels by typ. 50 ms.
Conversion cycle of unused input channels	Input channels configured as "unused" are skipped, i.e. they do not need any conversion time.

Examples for the conversion cycle

Example No.	1	2	3	4	5	6
Channels configured for U/I	1	8 *	-	-	2	4
Channels configured for Pt100	-	-	4	8	2	4
Channels configured as "unused"	7	-	4	-	4	-
Conversion cycle of U/I channels	1 ms	8 ms	-	-	4 ms	8 ms
Conversion cycle of Pt100 channels	-	-	200 ms	400 ms	200 ms	400 ms

* Factory setting

Resolution	10 to 12 bits, depending on the configuration, see also Fig. 4-19								
Resolution	<table> <tr> <td>range ± 10 V</td> <td>ca. 5 mV</td> </tr> <tr> <td>range 0...10 V</td> <td>ca. 5 mV</td> </tr> <tr> <td>range 0...20 mA</td> <td>ca. 5 μA</td> </tr> <tr> <td>range 4...20 mA</td> <td>ca. 4 μA</td> </tr> </table>	range ± 10 V	ca. 5 mV	range 0...10 V	ca. 5 mV	range 0...20 mA	ca. 5 μ A	range 4...20 mA	ca. 4 μ A
range ± 10 V	ca. 5 mV								
range 0...10 V	ca. 5 mV								
range 0...20 mA	ca. 5 μ A								
range 4...20 mA	ca. 4 μ A								
Relationship between input signal and hex code	-100 %...0...+100 % = 8008 _H ...0000 _H ...7FF8 _H (-32760...0...32760 decimal)								
Conversion inaccuracy caused by non-linearity, temperature sensitivity, ageing, adjustment error on delivery and resolution: U, I Pt100	typ. 0.5 %, max. 1 % typ. 1 °C, max. 2 °C								
Threshold, if analog input is configured as digital input	ca. 7 V								
Max. cable length, 2-core shielded and cross section $\geq 0,5$ mm ²	100 m								

4.7.8 Analog outputs

Number of channels per module	4
Reference potential	AGND2 (channels 06,00...06,03)
Electrical isolation	none (see also Fig. 4-4).
Max. permissible potential difference between Terminal M (minus pole of the power supply voltage) and terminal AGND (analog I/O minus pole)	± 1 V
Signalling of output statuses	none
Output signal ranges (configurable)	-10 V...0...+10 V 0...20 mA 4...20 mA

Output load capability of the voltage outputs	max. ±3 mA
Resolution	12 bits
Resolution (1 LSB), range –10 V...0...+10 V	5 mV
Relationship between output signal and hex code	-100 %...0...+100 % = 8008 _H ...0000 _H ...7FF8 _H (-32760...0...32760 decimal)
Conversion cycle for outputs	typ. 1 ms for each configured output channel
Conversion inaccuracy caused by non-linearity, temperature sensitivity, ageing, adjustment error on delivery and resolution	typ. 0.5 %, max. 1 %
Max. cable length, 2-core shielded and cross section ≥ 0,5 mm ²	100 m
4.7.9 Connection of serial interface COM1	
Interface standard	EIA RS-232
Programming with 907 PC 33 + 907 PC 331	with IBM PC (or compatible)
Man-machine communication	yes, e.g. with an operating station
Display and updating of timers, counters and parameters	yes
Electrical isolation	versus digital inputs and outputs, versus CS31 system bus interface (see also Fig. 4–4)
Potential differences	In order to avoid potential differences between the 07 KT 94-S basic unit and the peripheral device connected to the COM1 interface, this device is supplied from the switch-gear cabinet socket (see also the earthing connections in Fig. 4-5).
Pin configuration and description of the COM1 interface	see chapter 4.4.10
4.7.10 Connection of serial interface COM2	
Interface standard	EIA RS-232
Man-machine communication	yes, e.g. with an operating station
Electrical isolation	versus digital inputs and outputs, versus CS31 system bus interface (see also Fig. 4–4)
Potential differences	see COM1
Pin configuration and description of the COM2 interface	see chapter 4.4.11
4.7.11 Connection to the CS31 system bus	
Interface standard	EIA RS–485
Connection as a Master PLC as a Slave PLC	yes, transmitting and receiving areas are configurable yes, see chapter "System constants" (Appendix B7.3)
Setting of the CS31 module address	yes, by system constant, stored in Flash EPROM of the Slave PLC
Electrical isolation	versus supply voltage, inputs and outputs, versus interfaces COM1/COM2 (see also Fig. 4-4)
Terminal assignment and description of the CS31 bus interface	see chapter 4.4.3

4.7.12 LED displays

LEDs for indication of:

– Statuses of digital inputs	1 green LED per channel
– Statuses of digital outputs	1 yellow LED per channel
– Statuses of digital inputs/outputs	1 yellow LED per channel
– Power supply on	1 green LED
– Battery	1 red LED
– Program is running (RUN)	1 green LED
– Error classes (FK1, FK2, FK3)	1 red LED per error class
– CS31 system bus is running (BA)	1 green LED
– bus-specific errors (BE, RE, SE)	3 red LEDs
– Overload/short-circuit of digital outputs	1 red LED

4.7.13 High-speed hardware counter (see 4.6 High-speed counter)

Data of the integrated high-speed hardware counter:

Configurable	in 7 operating modes
Counting range	-32768...+32767 (16 bits)
Counting frequency	max. 50 kHz
Used inputs	E 62,00 and E 62,01
Used outputs	A 62,00

4.7.14 Mechanical data

Mounting on DIN rail	according to DIN EN 50022–35, 15 mm deep. The DIN rail is located in the middle between the upper and the lower edge of the module.
Fastening by screws	with 4 screws M4.
Width x height x depth	240 x 140 x 85 mm
Wiring method	by removable terminal blocks with screw-type terminals
Power supply terminals, CS31 system bus	max. 1 x 2.5 mm ² or max. 2 x 1.5 mm ²
All other terminals	max. 1 x 1.5 mm ²
Weight	1.6 kg
Dimensions for mounting	see the following drawing

In order to be able to insert or remove the SmartMedia Card, 30 mm of free space is necessary beginning at the right edge of the housing. The SmartMedia Card has a width of 45 mm and a height of 37 mm.

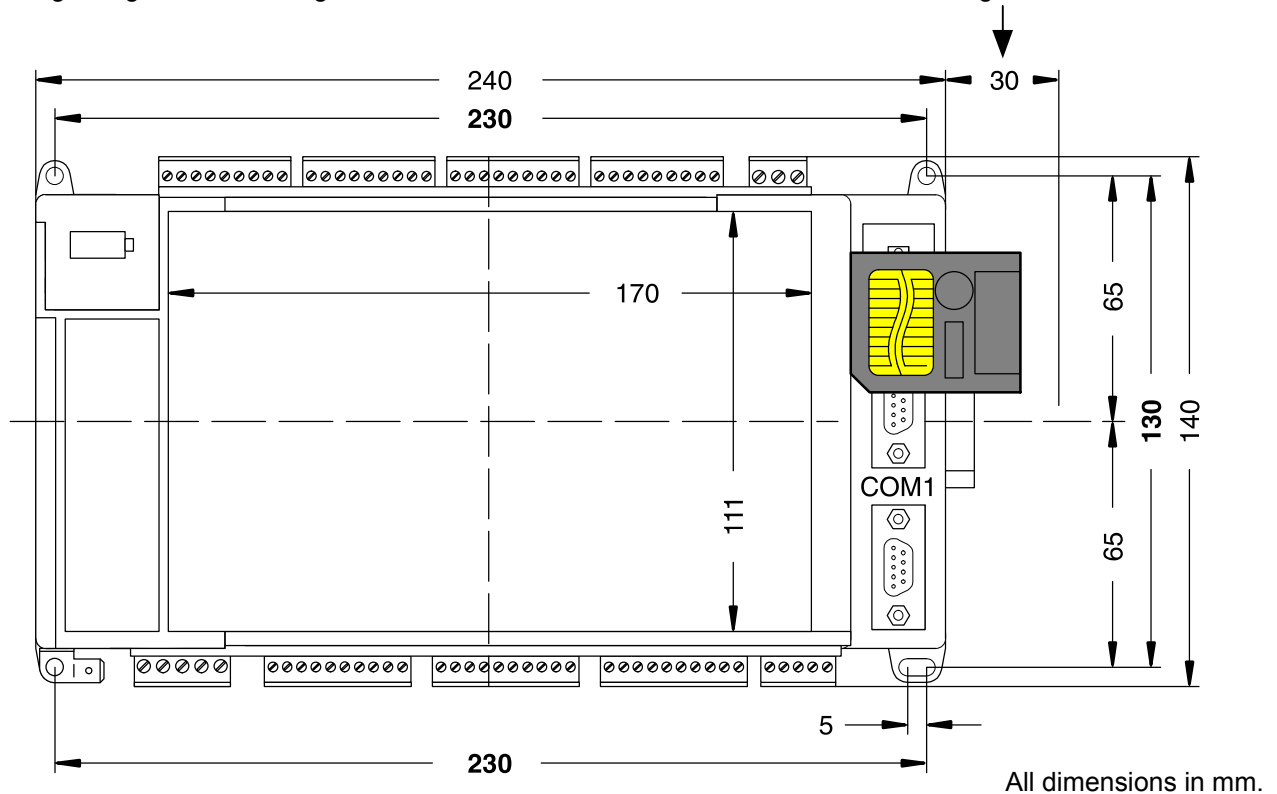

The device is 85 mm deep. The interface connectors COM1/COM2 are set deeper so that the mounting depth required does not become any larger even with detachable interface cables. If, however, a DIN rail is used, the mounting depth is increased by the overall depth of the rail.

The dimensions for assembly bore holes are printed in bold print.

4.7.15 Mounting hints

Mounting position

vertical, terminals above and below

Cooling

The natural convection cooling must not be hindered by cable ducts or other material mounted in the switch-gear cabinet.

4.7.16 Ordering data

Basic unit 07 KT 94-S R2101 ohne ARCNET
Basic unit 07 KT 94-S R2161 mit ARCNET

Order No. GJR5 2521 00 R2101
Order No. GJR5 2521 00 R2161

Scope of delivery

Basic unit 07 KT 94-S
1 5-pole terminal block (5.08 mm)
1 3-pole terminal block (5.08 mm)
3 10-pole terminal blocks (3.81 mm)
4 9-pole terminal blocks (3.81 mm)
1 5-pole terminal block (3.81 mm)

Accessories

System cable 07 SK 90
System cable 07 SK 91
System cable 07 SK 92
Battery module 07 LE 90
SmartMedia Card 07 MC 90

Order No. GJR5 2502 00 R1
Order No. GJR5 2503 00 R1
Order No. GJR5 2504 00 R1
Order No. GJR5 2507 00 R1
Order No. GJR5 2526 00 R0101

Programming and test software and operating manual (both 907 PC 33 and 907 PC 331 are required)

907 PC 33 German 1)
907 PC 33 English 1)
907 PC 331 German 2)
907 PC 331 English 2)

Order No. GJP5 2039 00 R302
Order No. GJP5 2040 00 R302
Order No. GJP5 2045 00 R402
Order No. GJP5 2046 00 R402

Further literature

System description Advant Controller 31 German
System description Advant Controller 31 English

Order No. 1SAC 1316 99 R0101
Order No. 1SAC 1316 99 R0201

1) Description General Part

2) Description 07 KR 91, 07 KT 92, 07 KT 93, 07 KT 94-S Specific Part + Software diskettes